

Glow•worm

Flue Installation

High Efficiency
Condensing
Boilers

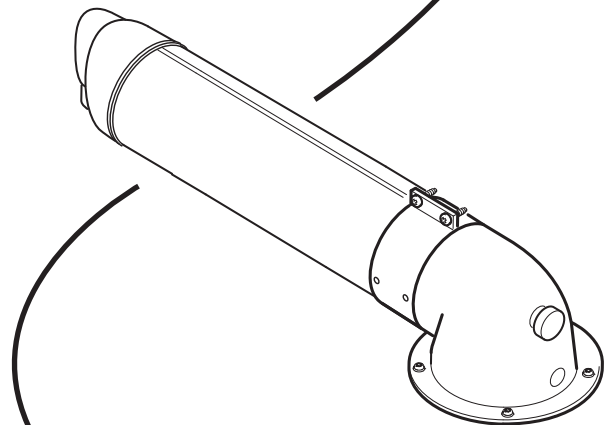
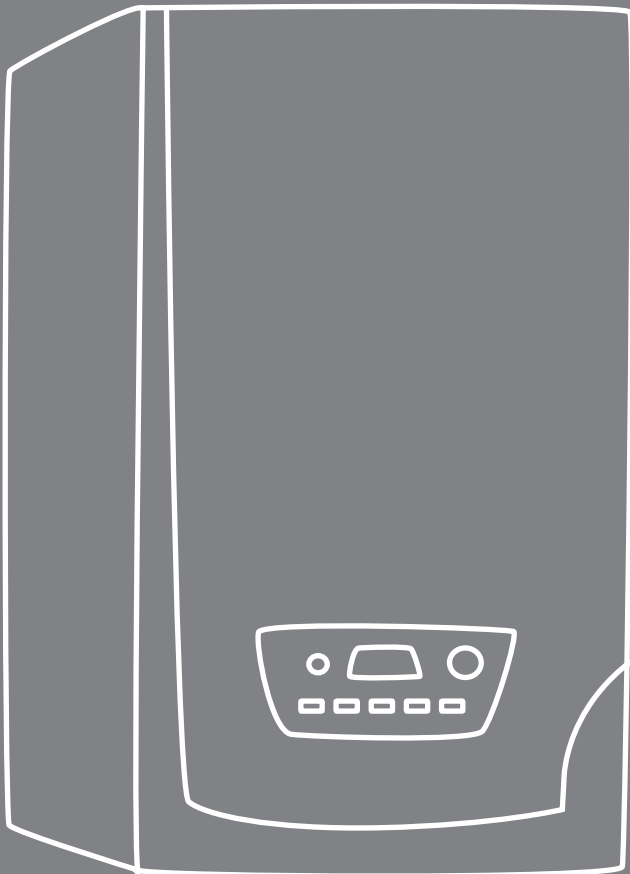

TABLE OF CONTENTS

INTRODUCTION

| | | |
|---|----------------------------------|---|
| 1 | Instruction guidance..... | 4 |
| | 1.1 Product documentation..... | 4 |
| | 1.2 Explanation of symbols | 4 |
| | 1.3 Important Notes | 4 |

INSTALLATION

| | | |
|---|---|----|
| 2 | Telescopic Direct Rear Flue Kit Ø60/100 - Pt. No. A2043500..... | 7 |
| | 2.1 Flue Length and Terminal Position | 7 |
| | 2.2 External Flue Installation | 8 |
| | 2.3 Internal Flue Installation | 8 |
| 3 | Top Horizontal Telescopic Flue Kit Ø60/100 - Pt. No. A2043600 | 9 |
| | 3.1 Flue Length and Terminal Position | 9 |
| 4 | Top Horizontal Standard Flue Kit Ø60/100 - Pt. No. A2043400 | 11 |
| | 4.1 Flue Length and Terminal Position | 11 |
| | 4.2 Flue Cutting | 11 |
| | 4.3 Flue Fitting..... | 12 |
| 5 | Vertical Concentric Flue System Ø60/100 - Pt. No. A2043400..... | 13 |
| | 5.1 Flue Length and Terminal Position | 13 |
| | 5.2 Flue Installation | 13 |
| | 5.3 Flue Terminal..... | 14 |
| | 5.4 Ridge Tile Terminal..... | 15 |
| | 5.5 Flue Terminal Cutting..... | 15 |
| | 5.6 Flue Extension Completion..... | 15 |
| 6 | Accessories..... | 16 |
| | 6.1 Deflector Flue Terminal Kit Ø60/100..... | 16 |
| | 6.2 Installation | 16 |
| | 6.3 Black Terminal Kit Ø60/100 | 17 |
| | 6.4 Installation | 17 |
| | 6.5 Plume Management Kit Ø60/100 | 18 |
| | 6.6 Terminal Siting..... | 19 |
| | 6.7 Installation | 20 |
| | 6.8 Termination above eaves..... | 22 |
| | 6.9 Termination..... | 22 |
| | 6.10 Fixing Instructions..... | 22 |
| 7 | Flue Systems and Components..... | 23 |
| | 7.1 Top Horizontal Standard Flue Ø80/125..... | 24 |
| | 7.2 Flue Length and Terminal Position | 24 |
| | 7.3 Extension Cutting | 24 |
| | 7.4 Installing the Sliding Sleeve | 24 |
| | 7.5 Fitting Elbows | 25 |
| | 7.6 Flue Terminal Assembly Fitting..... | 25 |
| | 7.7 Horizontal Flue Roof Termination | 25 |
| | 7.8 Vertical Concentric Flue Ø80/125..... | 26 |
| | 7.9 Flue Length and Terminal Position | 26 |
| | 7.10 Pitched Roof Terminal Installation | 26 |
| | 7.11 Flat Roof Terminal Installation | 27 |
| | 7.12 Flue Terminal Cutting..... | 27 |
| | 7.13 Fitting Air/Flue Duct Extensions..... | 27 |
| | 7.14 Fitting Elbows | 27 |

INTRODUCTION

1 Instructions guidance

1.1 Product documentation

The instructions are an integral part of the appliance and must be handed to the user on completion of the installation in order to comply with the current regulation.

- Carefully read the manual, to understand all the information to enable safe installation, use and servicing. No liability can be accepted in the event of damage for not complying with the guidance in this instruction manual.

1.2 Explanation of symbols



DANGER: Risk of injuries.



DANGER: Risk of electric shock.



ATTENTION: Risk of damage to the appliance or to its surroundings.



IMPORTANT: Important information.

1.3 Important Notes

Read the following before installing your flue system!

Flue Options - 60/100

There are various flue systems as illustrated in diagram opposite.

1. Direct rear telescopic flue
2. Top horizontal telescopic flue.
3. Top horizontal standard flue.
4. Vertical concentric flue flue.

These systems are complimented with various accessories.

Flue Systems Concealed in Voids

In accordance with Building Regulations Part J: 2010 and the Gas Safe Register Technical Bulletin TB 008: For Boiler flue systems installed within any concealed enclosure (such as a ceiling space, floor void, or a purpose built enclosure), the entire flue system should be accessible. This is to allow proper inspection of the flue to determine that it is continuous and fully supported throughout its length and all joints are correctly assembled.

The maximum equivalent flue lengths are stated in the instructions provided with each appliance. These values must never be exceeded.

Multiple Boiler Chimney Flue - 60/100 (Flue category C43 natural draught)

Vertical concentric multiple flue is suitable for use with:-

- Top horizontal telescopic flue,
- Top standard horizontal flue,

Refer to your appliance installation instructions for information relating to flue length and installation.

Flue Options - 80/125

The two flue systems available are:

1. Top standard horizontal flue
2. Vertical concentric.

Flue Systems

The flue lengths available are described in the appropriate section of the Installation Instructions supplied with your appliance.

- The flue seals are sensitive to mineral oil based lubricants. Do not grease the seals. If the seals do need to be lubricated use only water.
- During the installation of the flue system, ensure that debris such as mortar, filings or swarf are cleared from the flue system before completion.
- Inspect the flue pipes before fitting and do not install damaged or dented flue components.
- When assembling the flue system, ensure that the inner seals are not damaged, do not install a flue component with a damaged seal.
- The flue can be installed from inside the building, when access to the outside wall face is not practicable.
- When extension pipes are used the flue system must be designed to have a continuous fall to the appliance of at least 2.5° 44mm/metre to allow condensate to run back into the appliance and out via the condensate drain.
- Long lengths of flues must be secured to the walls or ceilings they run against. Use at least one fixing bracket for every flue extension that is used.
- After cutting inner flue pipe ensure that you de-burr and chamfer the male tube end to prevent damage.
- Inspect the flue pipes before fitting and do not install damaged or dented flue components.
- When assembling the flue system, ensure that the inner seals are not damaged, do not install a flue component with a damaged seal.
- When fitting flue elbows ensure that they are fitted at the correct angle to avoid strain, this will ensure that the seal fits correctly preventing leakage.

Flue Clearances

The flues should be positioned so that at least the minimum operational and servicing clearances are provided, refer to the appropriate section of the installation literature supplied with your appliance. Additional clearances may be beneficial for installation and servicing.

For flue installations where external access is not practicable, consideration should be given for the space required to insert the flue internally, which may necessitate clearance larger than those specified.

Timber Frame Buildings

If the flue is to be installed in a timber frame building it should be fitted in accordance with the Institute of Gas Engineers document IGE/UP/7/1998.

If in doubt seek advice from Glow-worm or the advice line for registered gas installers provided by the body approved at the time by the Health and Safety Executive.

Combustible Material

The flue is suitable for installation onto and through combustible materials provided that a minimum 5mm clearance is maintained around the circumference of the flue (air intake).

1.3.1 Local regulations



Benchmark places responsibilities on both manufacturers and installers. The purpose is to ensure that customers are provided with the correct equipment for their needs, that it is installed, commissioned and serviced in accordance with the manufacturer's instructions by a competent person approved at the time by the Health and Safety Executive and that it meets the requirements of the appropriate Building Regulations. The Benchmark Checklist can be used to demonstrate compliance with Building Regulations and should be provided to the customer for future reference.

Installers are required to carry out installation, commissioning and servicing work in accordance with the Benchmark Code of Practice which is available from the Heating and Hotwater Industry Council who manage and promote the Scheme.

- Visit www.centralheating.co.uk for more information.

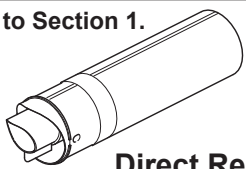
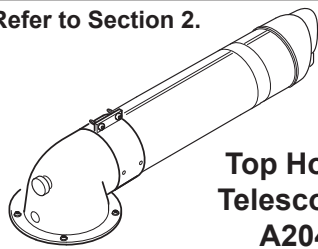
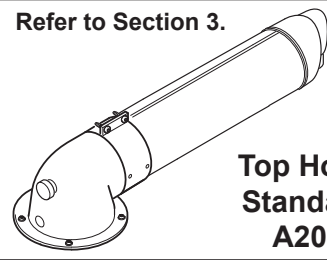
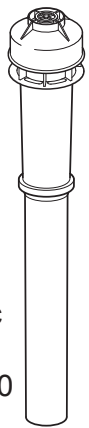
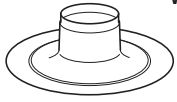
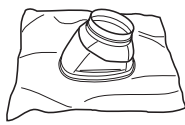
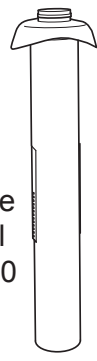
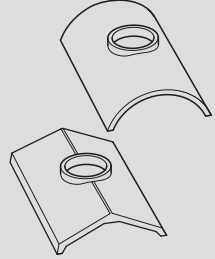
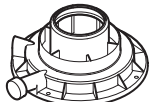

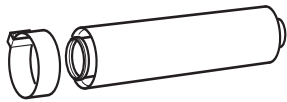
| Flue Systems | | | |
|---|--|--|--|
| <p>Refer to Section 1.</p>  <p>Direct Rear Telescopic Flue A2043500</p> | <p>Refer to Section 2.</p>  <p>Top Horizontal Telescopic Flue A2043600</p> | <p>Refer to Section 3.</p>  <p>Top Horizontal Standard Flue A2043400</p> | |
|  <p>Vertical Concentric Flue 2000460480</p> |  <p>Flat Roof Weather Collar 2000460478</p>  <p>Pitched Roof Weather Collar 2000460479</p> |  <p>Ridge Tile Terminal A2043800</p> |  <p>Special order contact: Tower Flue Components Morley Road Tonbridge Kent TN9 1RA</p> |
| <p>Refer to Section 4.</p> |  <p>Flue Adaptor A2024600</p> | | |
| <p>Vertical Concentric Flue 60/100</p> | | | |

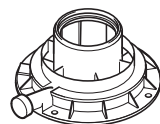
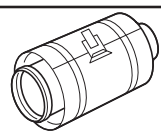
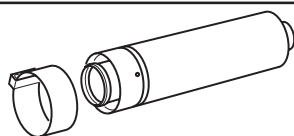
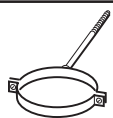
| Flue components Ø60/100 | Direct | Top telescopic | Top standard | Vertical |
|---|--------|----------------|--------------|----------|
| 0.5m Pt No. 2000460481 1m Pt No. 2000460482 2m Pt No. 2000460483 incl. securing collar  | X | ✓ | ✓ | ✓ |
| 45° Elbow Pt No. 2000460485 (pack of 2)  | X | ✓ | ✓ | ✓ |
| 87° Elbow Pt No. 2000460484  | X | ✓ | ✓ | ✓ |
| Vertical flue adaptor Pt No. A2024600  | X | ✓ | ✓ | ✓ |
| Sliding sleeve Pt No. 2000460487  | X | - | - | ✓ |
| Telescopic extension Pt No. 2036900 incl. securing collar  | X | - | - | ✓ |
| Fixing bracket Pt No. 2000460486 100 Ø  | X | ✓ | ✓ | ✓ |

INSTALLATION



All the drawings dimensions are shown in mm.

2 Telescopic Direct Rear Flue Kit Ø60/100 - Pt. No. A2043500



Direct rear flues are only possible with certain boilers, check the instructions provided with your boiler.

Check the contents of your kit.

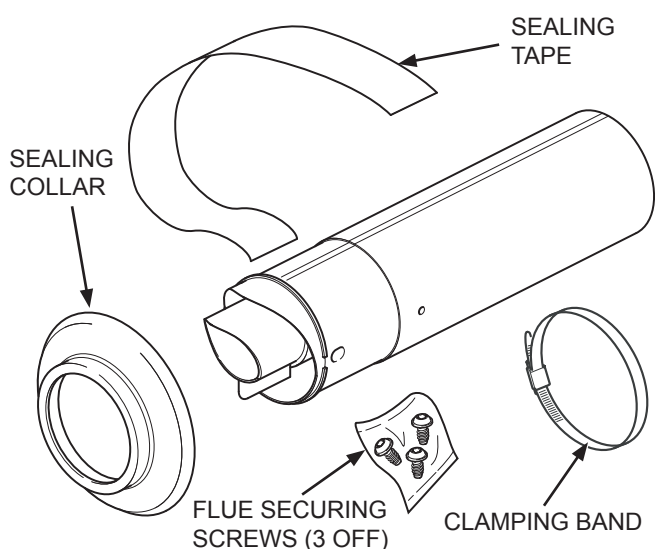

2.1 Flue length and Terminal position

Refer to your Installation instructions supplied with the appliance to confirm the flue length available and location of the flue terminal, then proceed as follows:

- Measure the distance from the external wall to the appliance mounting face "Y", see diagram below.
- Set the flue to the required length 'Y' plus 24mm min to 28mm max.

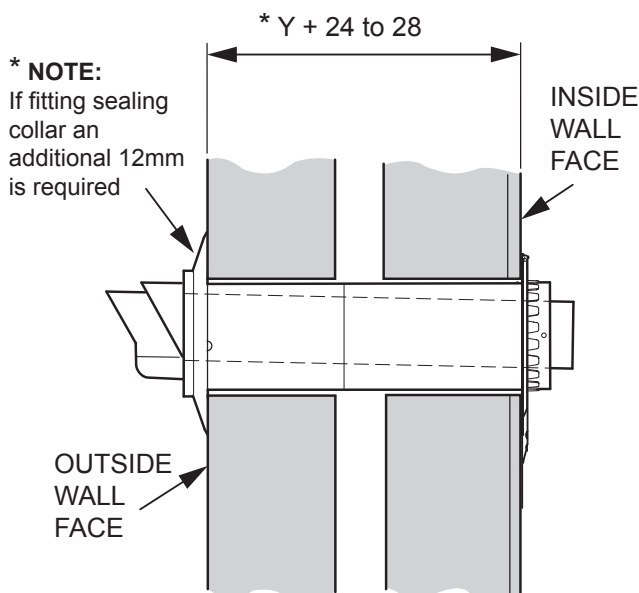

NOTE: If fitting the sealing collar, add a further 12mm to the overall length.

NOTE: DO NOT cut the telescopic flue, if the flue length cannot be achieved, the standard flue or extensions should be used. However if necessary the flue can project to a maximum of 600mm. beyond the outside wall face.

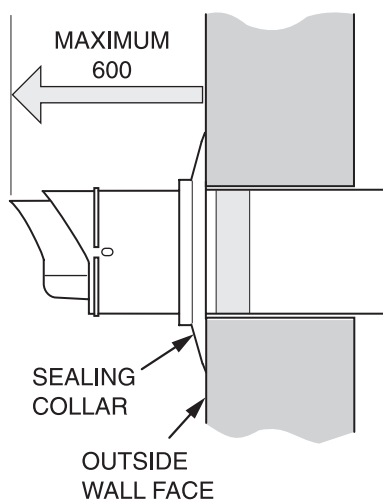

- Align the air duct seams.
- Mark and drill a 3mm hole in the air duct, taking care not to pierce the inner flue duct.
- Secure the joint with the screws and tape provided.

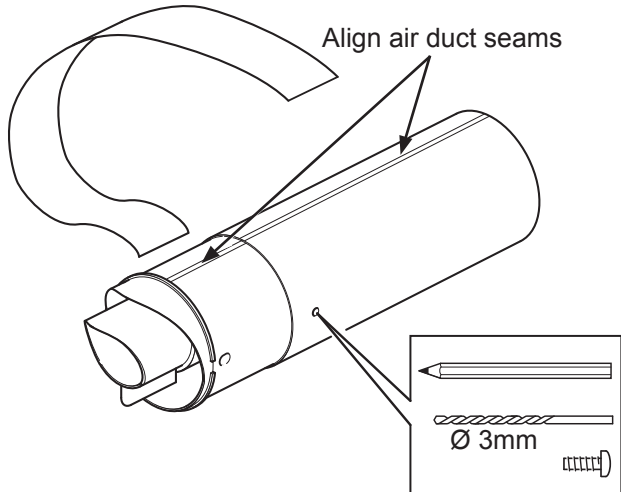

2.2 External Flue Installation

- If required, fit the sealing collar onto the locating ring of the flue terminal.

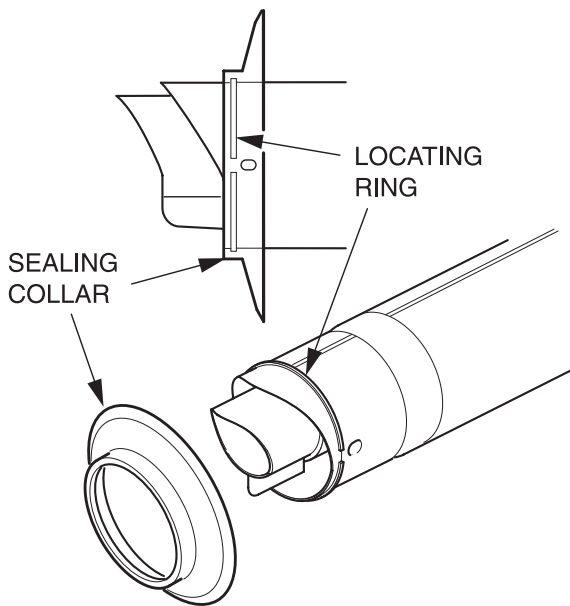

- Push the telescopic flue assembly into the wall and through the grips.
- Pull the flue assembly forward to the required depth shown in diagram, then secure using one of the described methods opposite.

2.3 Internal Flue Installation

- If required, fit the internal sealing collar onto the locating ring of the flue terminal.
- Push the telescopic flue assembly through the grips and wall, until the sealing collar has exited the hole.
- Pull the flue assembly forward to the required depth shown in diagram opposite, then secure using one of the described methods opposite:

Method 1. Securing Screws (3)

There are six holes provided in the grips, three of these should be used to secure the flue. Mark and drill 3mm holes in the air duct then secure to the grips with the screws provided.

Method 2. Clamping Band

Secure the telescopic terminal assembly using the clamping band supplied. The clamping band securing screw must be fitted in the correct orientation.

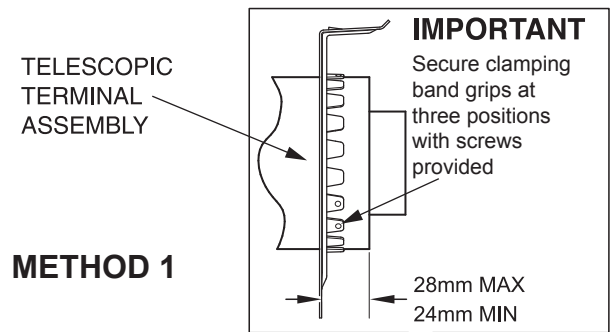

METHOD 1

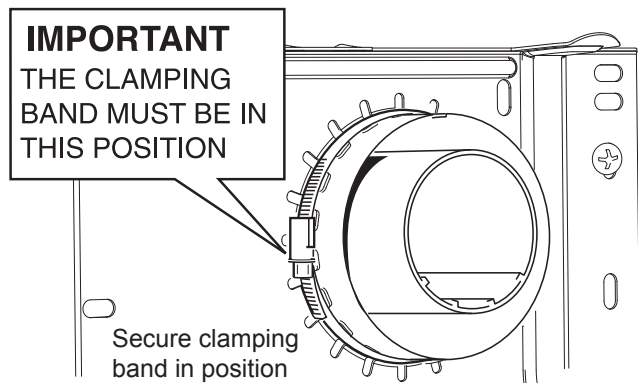
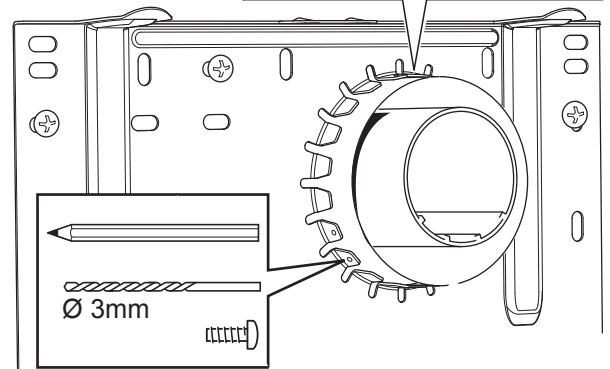

METHOD 2



Check that the flue air duct has been securely retained by the clamping band and grips before fitting the appliance.

On completion of flue installation, continue with the appliance installation, referring to the appropriate section of the appliance installation instructions supplied.

3 Top Horizontal Telescopic Flue Kit Ø60/100 - Pt. No. A2043600

Check the contents of your kit.

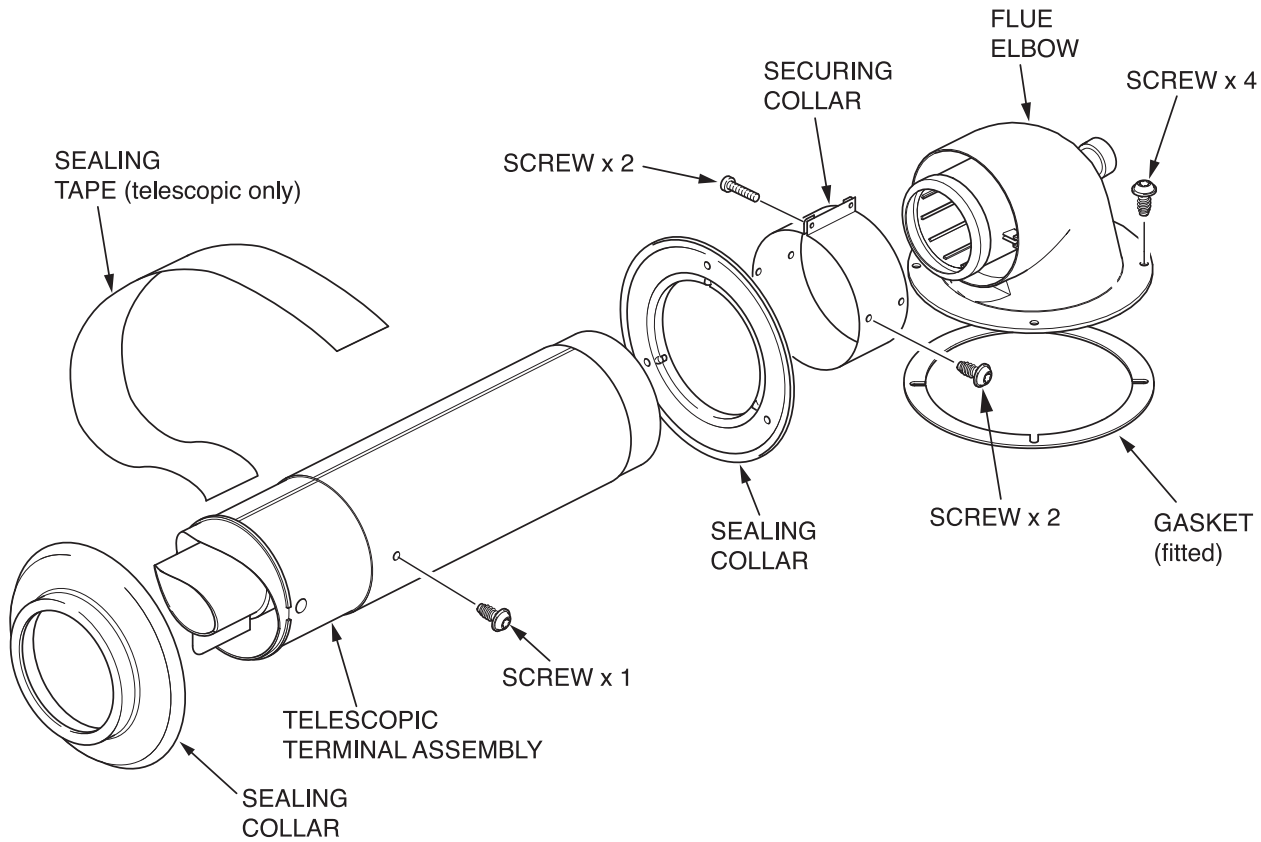

3.1 Flue length and Terminal position

Refer to your Installation instructions supplied with the appliance to confirm the flue length available and location of the flue terminal, then proceed as follows:

- With the flue elbow temporarily fitted, measure the distance from the external wall to the elbow.

NOTE: * If fitting the sealing collar, add a further 12mm to the overall length 'Y', see diagrams below.

- Set the flue ducts to the required length 'Y'. If the measurement 'Y' exceeds the telescopic flue length, then the appropriate length of extension pipe will be required.

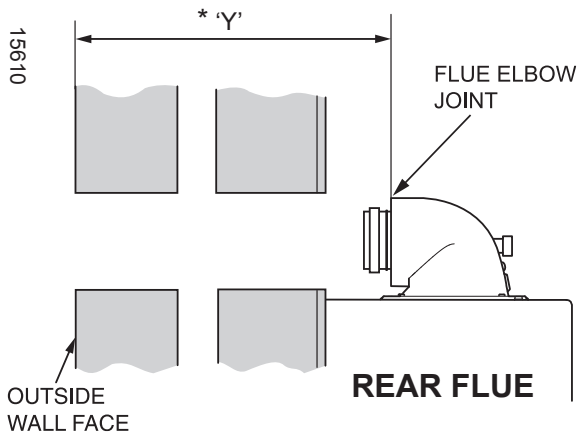
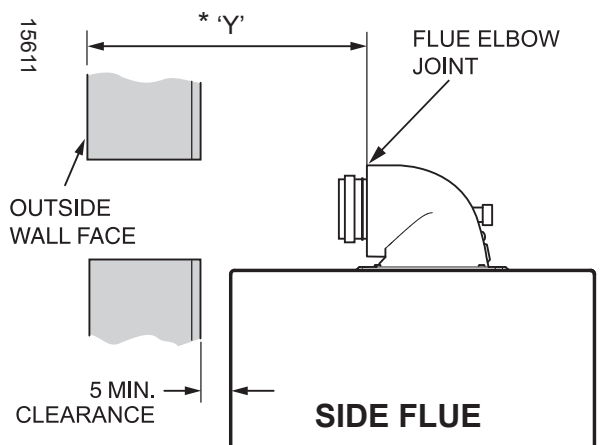

DO NOT cut the telescopic flue, if the flue length cannot be achieved, the standard flue or extensions should be used.

If desirable the flue can project to a maximum of 600mm beyond the outside wall face.

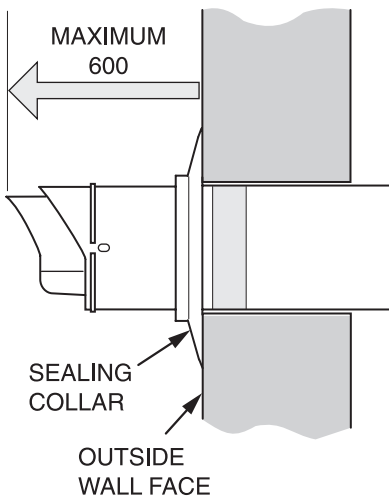

- Align the air duct seams.
- Mark and drill a 3mm hole in the air duct, taking care not to pierce the inner flue duct.
- Secure the joint with the screws and tape provided.

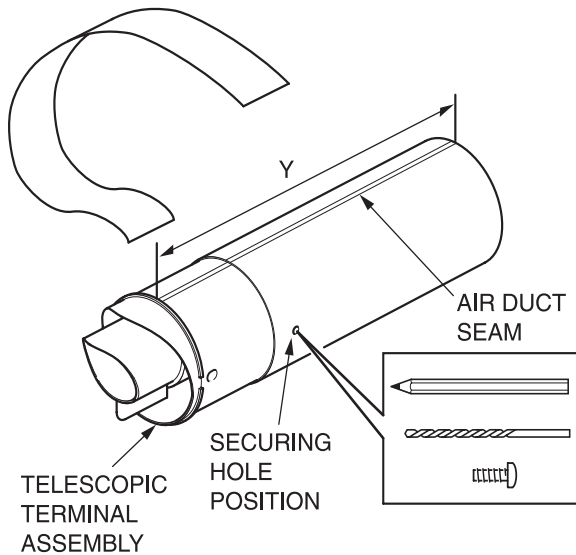

- If required, fit the sealing collar onto the locating ring of the flue terminal.

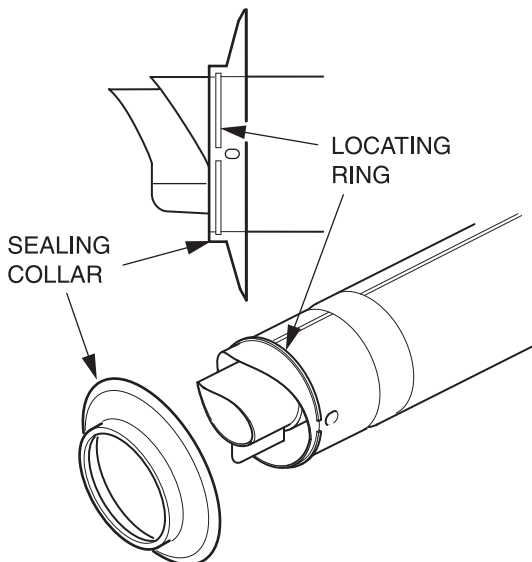

- Remove the flue elbow.
- Push the flue assembly into the wall, until the end of the assembly protrudes a short way from the inside face of the wall. This will enable the internal trim ring (if required) to be positioned and allow the flue assembly to be drawn back up to the flue elbow.
- Secure the flue elbow in position on top of the appliance with four screws supplied.
- Fit the flue assembly to the elbow.
- Fit the securing collar into position.
- Ensuring correct alignment of the air duct seam, mark through two of the pre drilled holes in the securing collar.
- Remove securing collar and drill two 3mm diameter holes one in the elbow and one in the air duct, take care not to pierce the inner flue duct. Secure collar and air duct with screws provided.

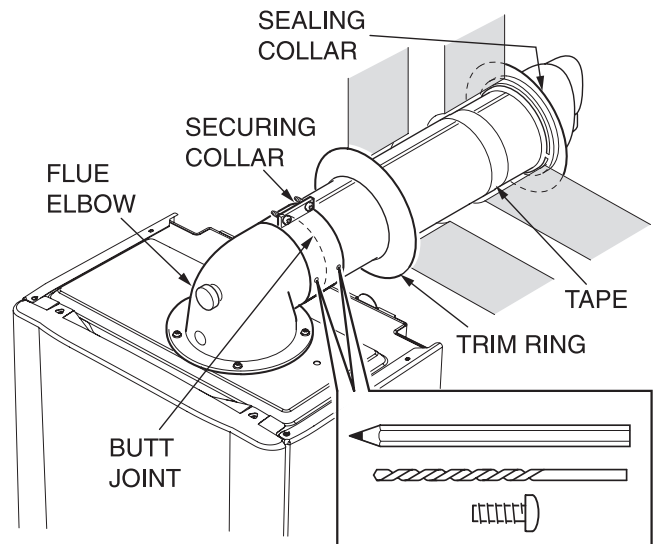

- Slide the internal trim ring back against the wall, securing in place with a small amount of sealant if required.
- Check that the outer rubber sealing collar makes an effective seal against the wall face.

On completion of flue installation, continue with the appliance installation, referring to the appropriate section of the appliance installation instructions supplied.

4 Top Horizontal Standard Flue Kit Ø60/100 - Pt. No. A2043400

Check the contents of your kit.

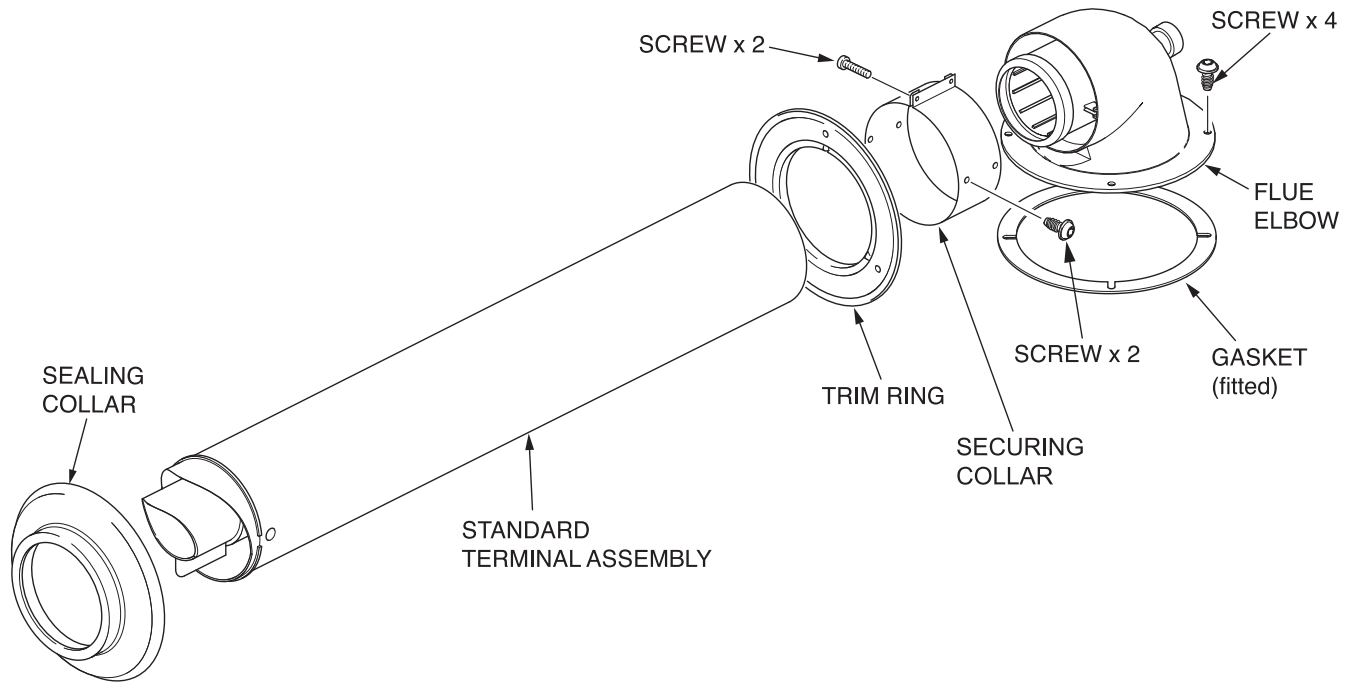

4.1 Flue length and Terminal position

Refer to your Installation instructions supplied with the appliance to confirm the flue length available and location of the flue terminal, then proceed as follows:

- With the flue elbow temporarily fitted, measure the distance from the external wall to the elbow.

NOTE: * If fitting the sealing collar, add a further 12mm to the overall length 'Y', see diagrams below.

- Set the flue ducts to the required length 'Y'. If the measurement 'Y' exceeds the telescopic flue length, then the appropriate length of extension pipe will be required.

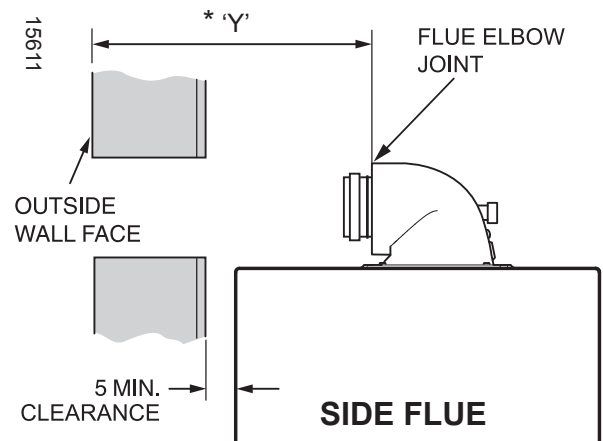
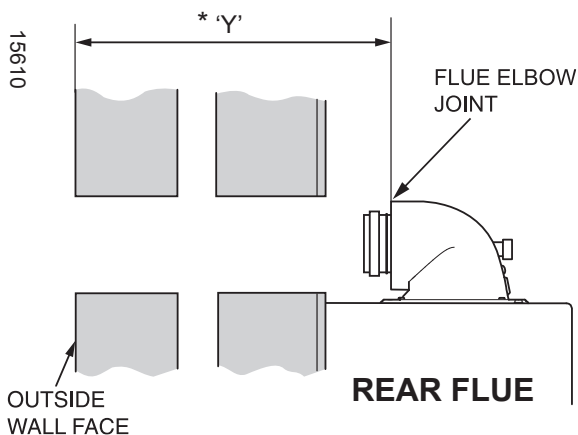

4.2 Flue Cutting

- Separate the flue duct from the terminal by twisting to release the terminal catch.

The flue duct cutting length is (L + 11mm), see diagram.

NOTE: If fitting the sealing collar, add a further 12mm to the overall length. However if desirable the flue can project to a maximum of 600mm beyond the outside wall face.

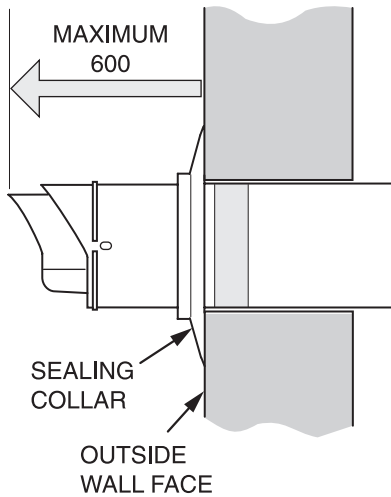

The air duct should be cut at the opposite end to the terminal and the plastic flue duct **MUST** be cut at the opposite end to the terminal catch.

The plastic flue duct extensions **MUST** be cut at the opposite end to seal.

- Insert the flue duct into the air duct terminal assembly, remembering to engage the catch within the terminal.

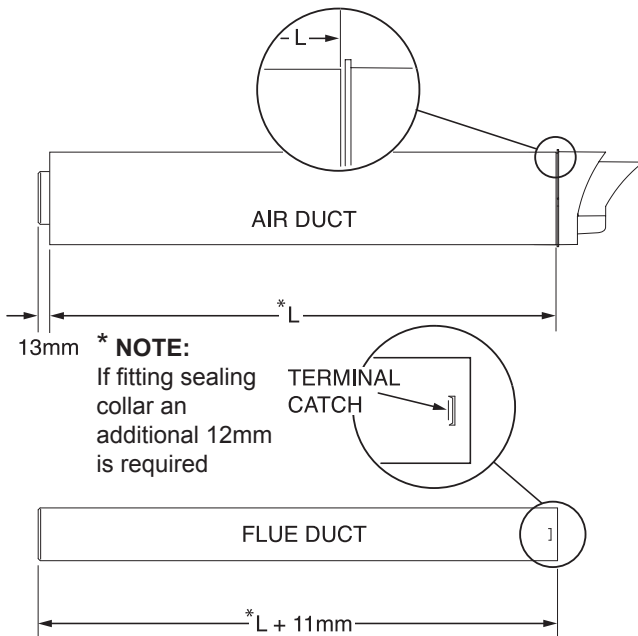

4.3 Flue Fitting

- Fit the sealing collar onto the locating ring on the flue terminal, see diagram 5.
- With the flue terminal removed, push the flue assembly into the wall, externally or internally, until the end of the assembly protrudes a short way from the inside face of the wall. This will enable the internal trim ring (if required) to be positioned and allow the flue assembly to be drawn back into the flue elbow.
- Secure the flue elbow in position on top of the appliance with four screws supplied.

- Fit the flue assembly to the flue elbow.
- Fit the securing collar into position.

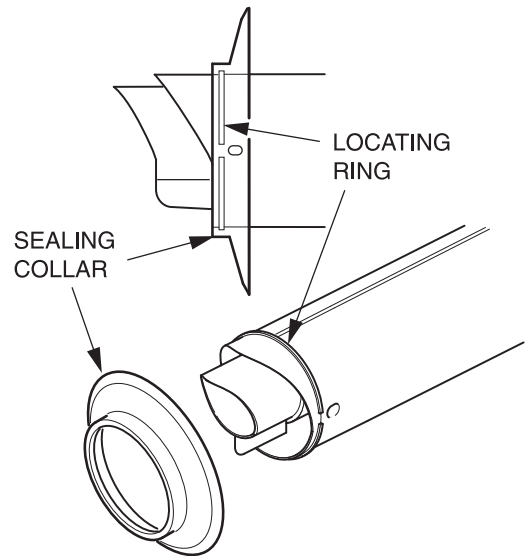

- Ensuring correct alignment of the flue, mark through two of the pre drilled holes in the securing collar.
- Remove securing collar and drill two 3mm diameter holes one in the elbow and one in the air duct, take care not to pierce the inner flue duct, secure collar with screws provided.

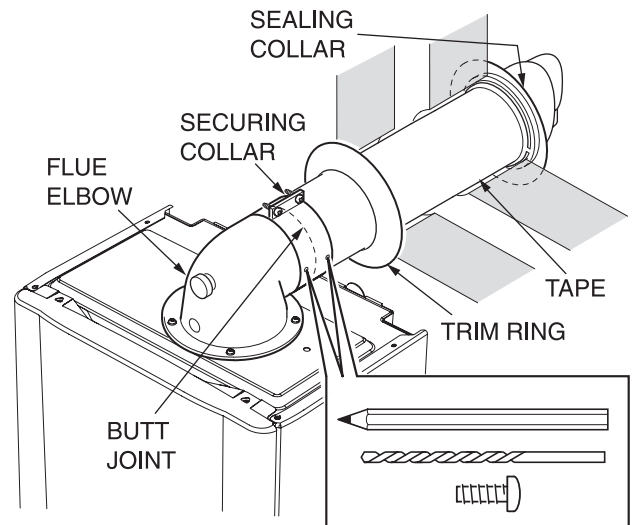

- Slide the internal trim ring back against the wall, securing in place with a small amount of sealant if required.
- Check that the outer rubber sealing collar makes an effective seal against the wall face.

NOTE: If the air and flue ducts have been correctly cut to the instructions the sealing collar should fit flush with the outside wall.

On completion of flue installation, continue with the appliance installation, referring to the appropriate section of the appliance installation instructions supplied.

5 Vertical Concentric Flue System Ø60/100 - Pt. No. 2000460480

Comprises of components selected to suit your site requirements, refer to Flue components table.

Make sure you have all the necessary components before proceeding with the installation.

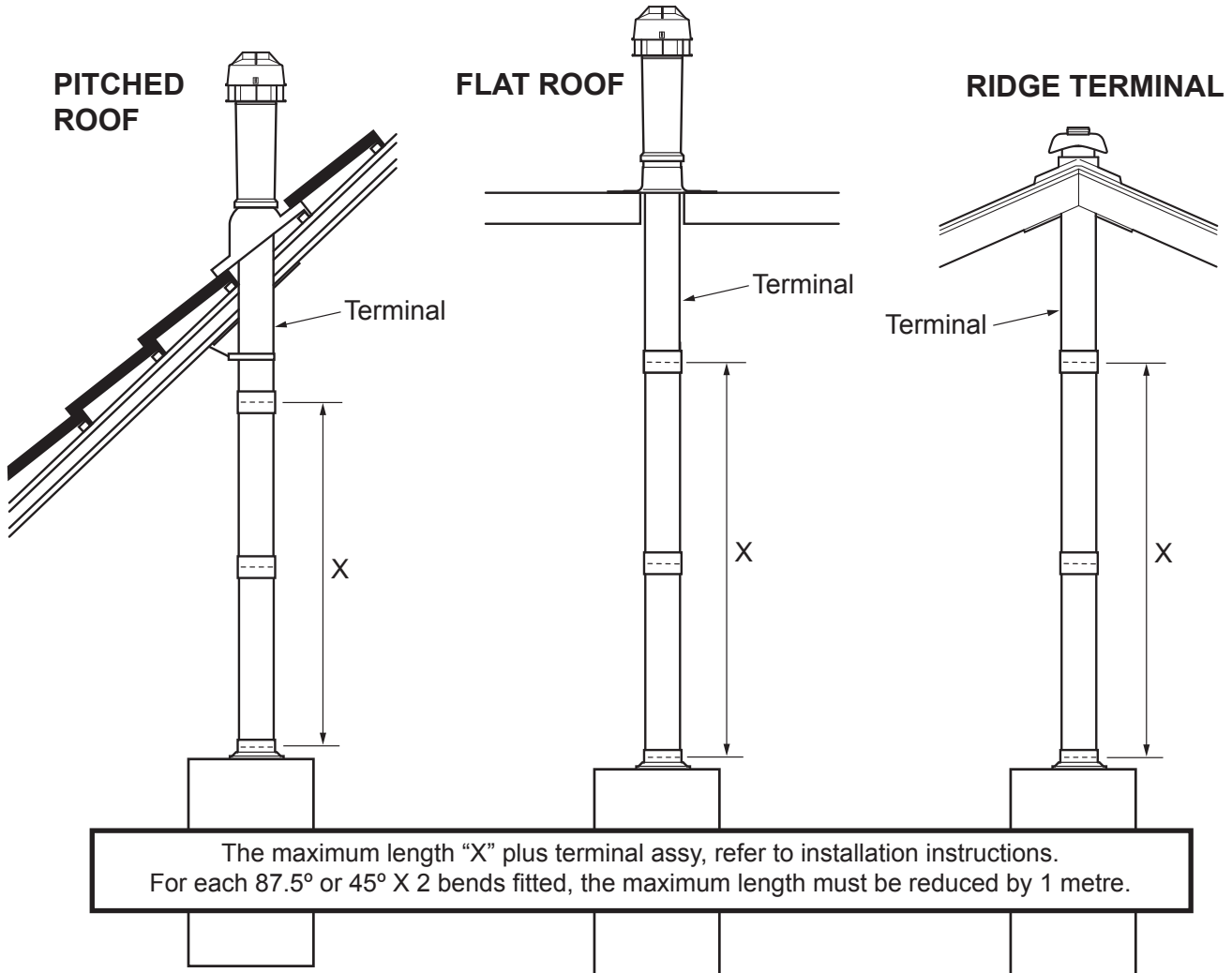

5.1 Flue Length and Terminal Position

The maximum flue length and terminal position are described in your installation instructions supplied with your appliance.

5.2 Flue Installation

Secure the flue adapter in position on top of the appliance with four screws supplied.

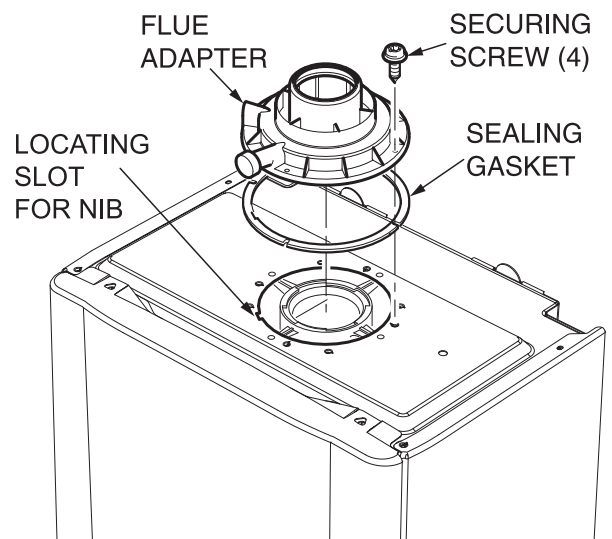



Make sure the nib fits into the locating slot in the appliance casing to ensure correct orientation.

With the flue adapter fitted, measure the flue length required.



The use of a sliding sleeve will allow the appliance to be easily removed and replaced without dismantling the flue.



Ensure that at least one fixing bracket supports each extension pipe used.



DO NOT connect the final extension until the flue terminal has been positioned.

- Secure the extension pipe to the flue adapter with the securing collar supplied, by positioning the collar centrally over the joint then tightening the two screws on the securing collar.

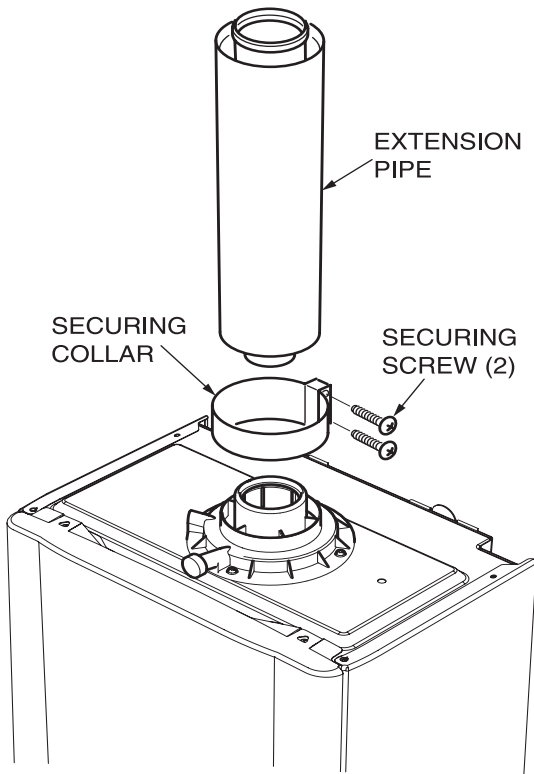

- Fit additional extension pipes as required using the collar and screws supplied with each extension pipe.
- To fit, position the collar centrally over the joint and tighten the two screws on the securing collar.
- Using the holes provided in the securing collar drill and insert the two self tapping screws supplied, see diagram 6. The rubber 'O' rings of each section should be lubricated prior to assembly.
- Project the rise of the flue to roof level. The flue terminal will require a 150mm hole.

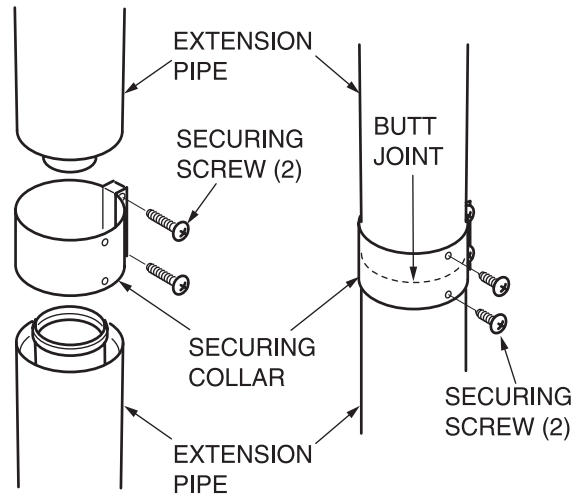

5.3 Flue Terminal Installation

Pitched Roof

Fit the required pitched roof weather collar over the 150mm hole in the roof. Make good the tiling or slating around the collar incorporating the flashing of the weather collar. Position the angle cap over the weather collar in the correct orientation to attain the correct angle for your roof.

Flat Roof

Fit the aluminium weather collar over the 150mm hole in the roof ensuring a weather tight seal.

From above carefully place the flue terminal through the weather collar.

5.4 Ridge Tile Terminal

A ridge tile terminal is available - part no. A2043800, see Flue Systems at the front of this literature.

The installation of a ridge tile will be required.

A suitable ridge tile is manufactured by: -

Aspect East Anglia Limited

The Old Mill

East Harling

NORWICH

NR16 2QW

Website: www.aspectroofing.co.uk

Contact: Chris Haythorpe

General Manager - Tile Division

Tel: 01953 717777 Fax: 01953 717164

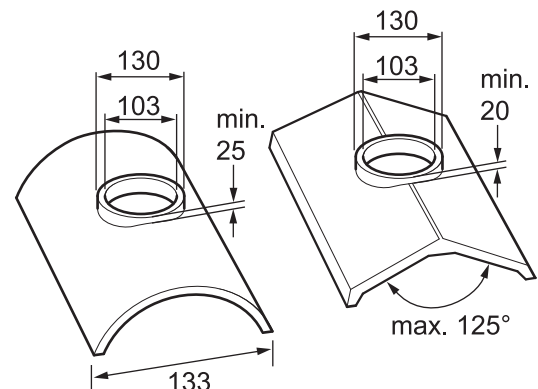

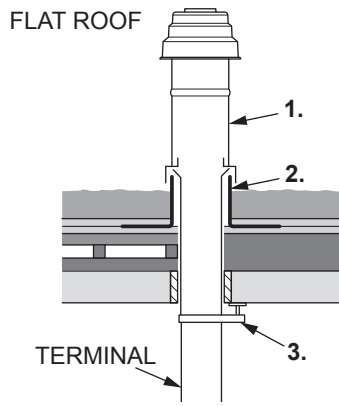

5.5 Flue Terminal Cutting

Should the clearances above the appliance to the flue terminal not allow for extensions, it is permitted to cut the flue terminal ensuring the relationship of flue and air duct lengths are retained.

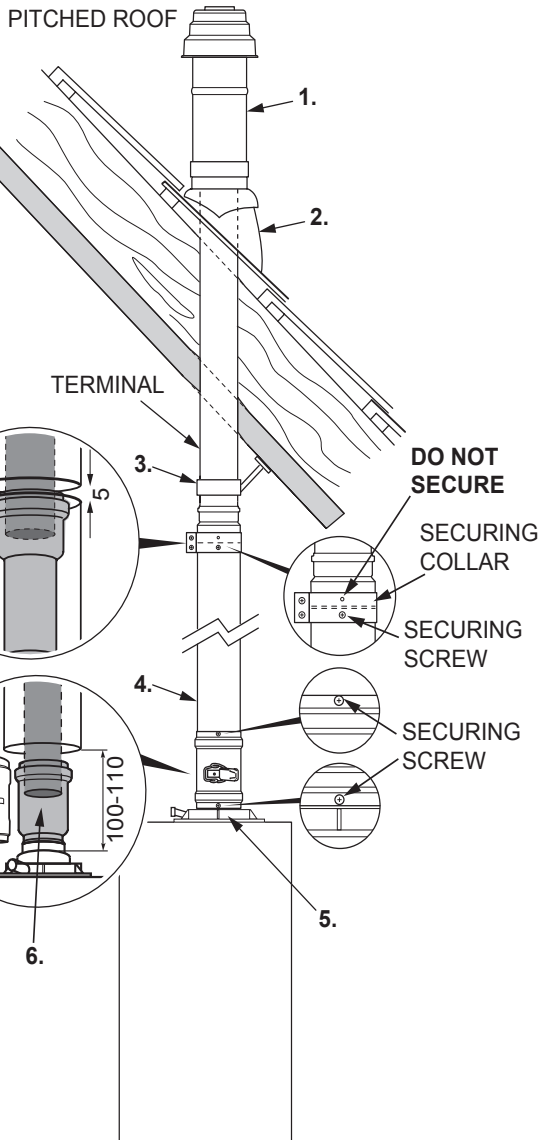

5.6 Flue Extension Completion

With the flue terminal positioned in the roof, measure the length of the pipe required to complete the connection between terminal and extension. If a telescopic length cannot be used, then an extension pipe can be cut to the correct length. Cut the flue to the desired length measuring from the 'O' ring end and discard the plain end of the tube. The cuts must be square and made free of burrs to allow correct assembly.

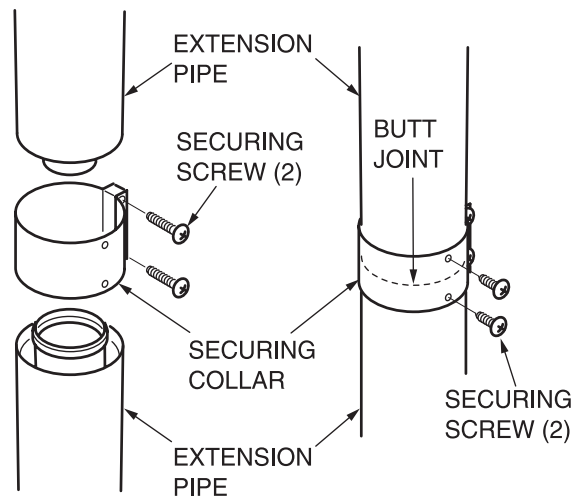

NOTE: The flue pipe is 10mm longer than the air pipe.

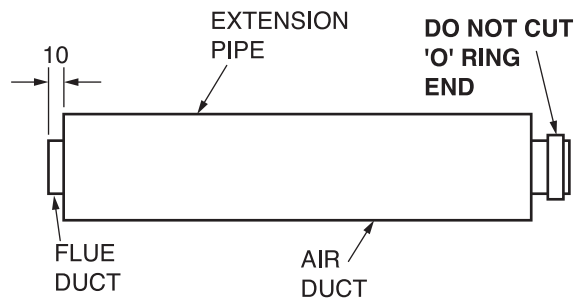

Carefully push the terminal assembly upwards to allow room for fitting the final flue piece. Fit a fixing bracket to the terminal assembly. Pull the terminal assembly down and join to the flue system. Ensure that the terminal is making a weather tight seal on the weather collar. Secure the fixing bracket fitted to the terminal to the roofing struts or a purpose made baton.

6 Accessories

6.1 Deflector Flue Terminal Kit Ø60/100

Check the contents of your kit.

Part No. 0020060582 - Black
Part No. 0020060583 - White

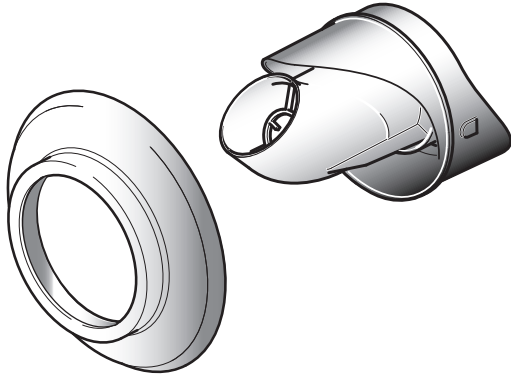

The Deflector Flue Terminal kit will fit either the telescopic or standard horizontal flue systems and is designed to be rotated 45° from the top centre, directing the plume away from openings, people, cars, windows etc.

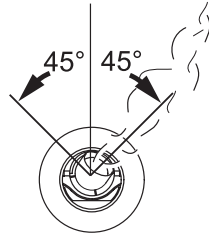
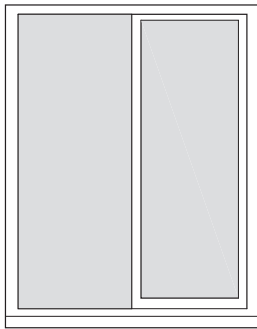

It can be fitted after the appliance and flue have been installed.

Should the deflector terminal be positioned under a soffit or horizontal surface, it is allowed to project the flue 600mm from the wall, to allow the discharge of flue gases produced into free air.



Do not fit the deflector flue terminal with the deflector positioned downwards.

6.2 Installation

- If previously fitted, remove the rubber collar.
- Using a 8mm. flat screwdriver to release the catch.
- Withdraw the flue terminal and pipe from the duct.
- Remove the flue pipe from the terminal, twist and pull, discard the terminal.
- Locate the "notch" on the pipe, align with the "catch" on the deflector terminal and push the pipe into position, ensuring that the engagement is secure.

- Fit the rubber collar
- Rotate the deflector to suit your requirements.
- Releasing Strap.

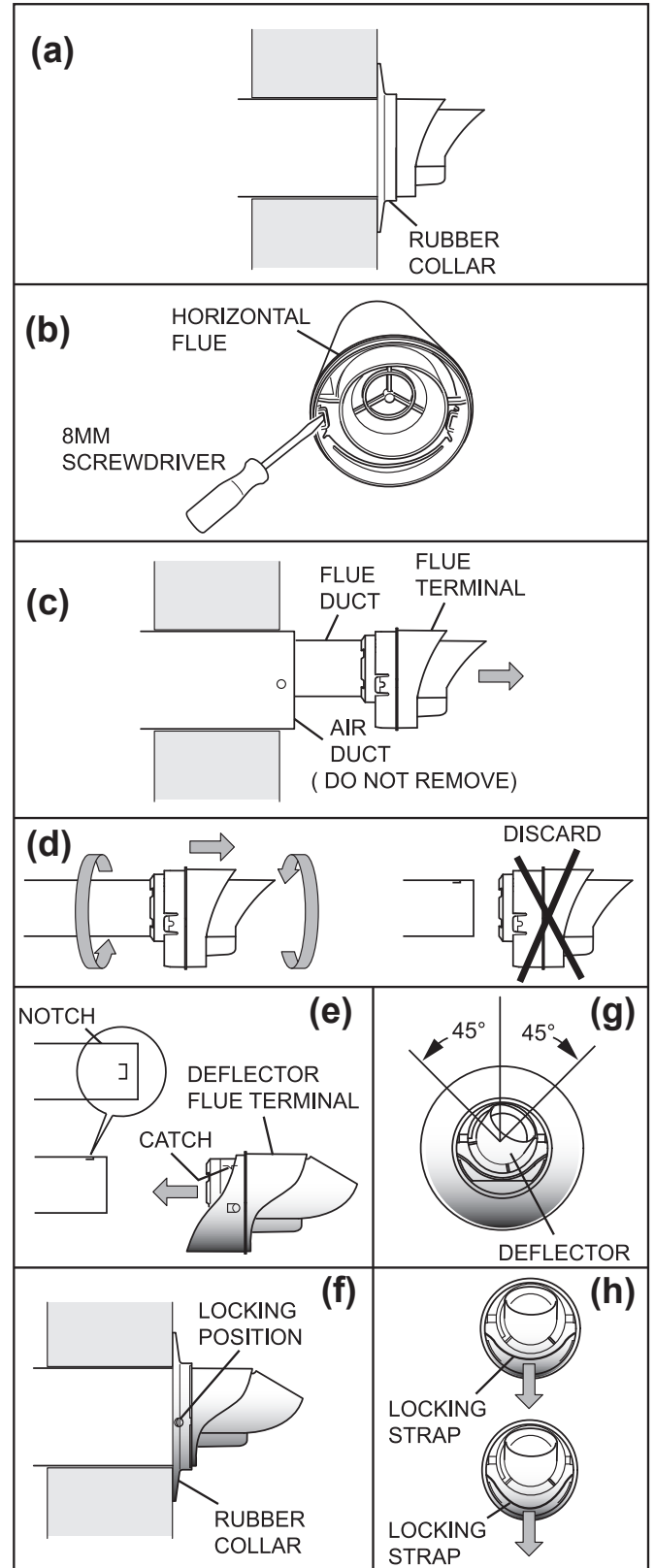

Push the flue pipe and terminal into the air duct, make sure the seals fit tightly.
 To remove deflector flue terminal from the air duct pull locking strap down (h), this will release both side locking positions (f).

6.3 BLACK Terminal Kit Ø60/100

Check the contents of your kit.

Part No. A2043700

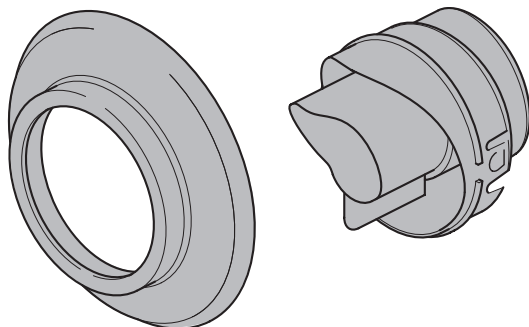

The Black Terminal kit will fit either the telescopic or standard horizontal flue systems and can be fitted after

the appliance and flue have been installed.

6.4 Installation

- (a) Using a 8mm flat screwdriver to release the catch.
- (b) Withdraw the flue terminal and pipe from the duct.
- (c) Remove the flue pipe from the terminal, twist and pull, discard the terminal.
- (d) Locate the “notch” on the pipe, align with the “catch” on the Black terminal and push the pipe into position, ensuring that the engagement is secure.
- (e) Fit the rubber collar.

Push the flue duct and terminal into the air duct make sure the seals fit tightly. **NOTE:** the seam of the air duct must be at the top.

6.5 Plume Management Kit Ø60/100

For use with concentric flue systems 60/100, part no.A2043400 and part no. A2043600. Check the contents of your kit.

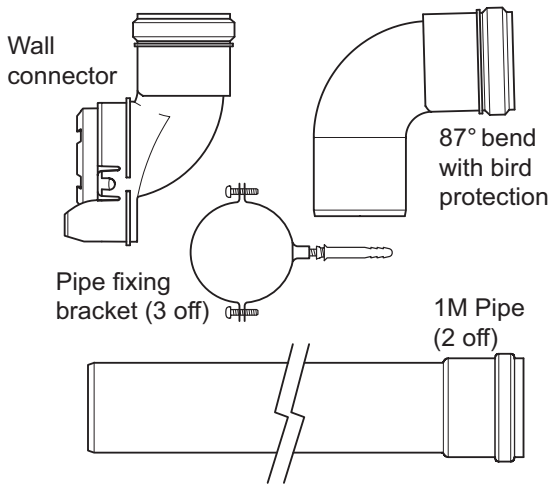

Contents of Kit

White kit: A2044100, Black kit: A2044000

Flue length - The concentric and plume pipe can vary, but the maximum flue length, must not be exceeded.

The plume management kit fits onto the concentric horizontal flue terminal of the Glow-worm high efficiency appliances and enables the flue products to be routed further away from the appliance flue terminal, thereby reducing the visual impact of plumbing. It should not be used to overcome terminal positions which do not comply with standards or manufacturers instructions.

The flue outlet supplied terminates at 87° but can, if required, terminate vertically or at 45° by simply using the appropriate accessory.

Siting can either be on a wall face with the terminal exhausting at right angles to the wall or above the eaves of a building. We recommend that terminals exhausting vertically above the eaves are secured.

The termination of the plume management kit, should not be less than 2 metres above ground level.

Plume and Concentric Flue Length

***NOTE:** For every elbow the flue pipe length should be reduced by the following amounts:

1 x 90° = 1 metre

2 x 90° = 2 metres

1 x 45° = 0.5 metres

2 x 45° = 1 metre

The total flue length (plume management kit + concentric) must not exceed the maximum total flue length of the appliance.

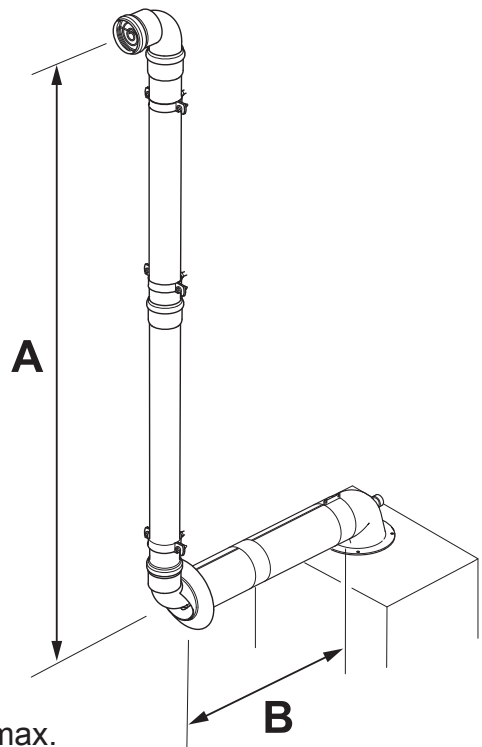

Example: Ultracom, "A" = 4.0m + "B" = 6.0m = 10.0m max.

| | | "A" FLUE PIPE LENGTH (metres) | | | | | | | | | | | | "A" + "B" MAXIMUM COMBINED FLUE LENGTH |
|-----------------|-------------|-------------------------------|-----|-----|-----|-----|-----|-----|-----|-----|-----|-----|-----|--|
| | | 0.5 | 1.0 | 1.5 | 2.0 | 2.5 | 3.0 | 3.5 | 4.0 | 4.5 | 5.0 | 5.5 | 6.0 | |
| "B" FLUE LENGTH | ULTRACOM | 9.5 | 9.0 | 8.5 | 8.0 | 7.5 | 7.0 | 6.5 | 6.0 | 5.5 | 5.0 | 4.5 | 4.0 | 10.0 |
| | FLEXICOM | 7.5 | 7.0 | 6.5 | 6.0 | 5.5 | 5.0 | 4.5 | 4.0 | 3.5 | 3.0 | 2.5 | 2.0 | 8.0 |
| | ULTRAPOWERS | 7.5 | 7.0 | 6.5 | 6.0 | 5.5 | 5.0 | 4.5 | 4.0 | 3.5 | 3.0 | 2.5 | 2.0 | 8.0 |
| | BETACOM 24C | 2.5 | 2.0 | 1.5 | 1.0 | - | - | - | - | - | - | - | - | 3.0 |
| | BETACOM 30C | 2.5 | 2.0 | 1.5 | 1.0 | - | - | - | - | - | - | - | - | 3.0 |
| | XTRAMAX HE | 4.5 | 4.0 | 3.5 | 3.0 | 2.5 | 2.0 | 1.5 | 1.0 | - | - | - | - | 5.0 |
| | ULTRACOM 2 | 9.5 | 9.0 | 8.5 | 8.0 | 7.5 | 7.0 | 6.5 | 6.0 | 5.5 | 5.0 | 4.5 | 4.0 | 10.0 |

6.6 Terminal Siting



Refer to the diagram below and the appropriate clearances for the flue outlet terminal in relation to openings, air inlet etc., these must be adhered to.

The minimum siting dimensions for the terminal positions, A, B, C stated in the diagram, can be applied when a plume management kit is fitted.

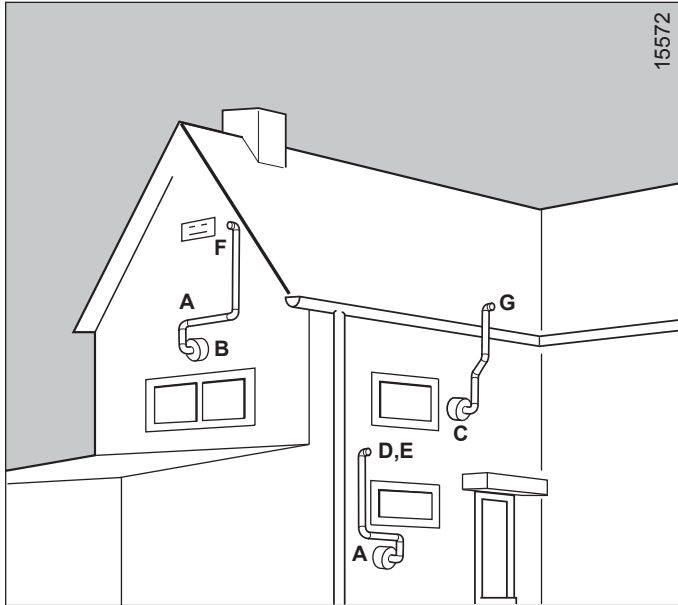

MINIMUM SITING DIMENSIONS FOR FANNED FLUE TERMINALS POSITION

MINIMUM SITING FOR HORIZONTAL FLUE AIR INLET MM

| | | |
|----|---------------------------------------|----|
| A) | DIRECTLY BELOW AN OPENING WINDOW | 50 |
| | DIRECTLY BELOW AN OPENING, AIR BRICK | 25 |
| B) | DIRECTLY ABOVE AN OPENING WINDOW | 50 |
| | DIRECTLY ABOVE AN OPENING, AIR BRICK | 25 |
| C) | HORIZONTALLY TO AN OPENING WINDOW | 50 |
| | HORIZONTALLY TO AN OPENING, AIR BRICK | 25 |

MINIMUM SITING FOR PLUME MANAGEMENT KIT FLUE OUTLET MM

| | | |
|----|--|-----|
| D) | DIRECTLY BELOW AN OPENING, AIR BRICK, OPENING WINDOWS (Horizontal Discharge) | 300 |
| E) | DIRECTLY ABOVE AN OPENING, AIR BRICK, OPENING WINDOWS (Horizontal Discharge) | 300 |
| F) | HORIZONTALLY TO AN OPENING, AIR BRICK, OPENING WINDOWS | 300 |
| G) | ABOVE ROOFLINE | 300 |

For further guidance on siting requirements consult BS 5440-1 : Table C.1

The minimum length is 500mm, three examples are shown in the diagrams below.

Additional elbows, bends and 1M extensions can be used as required.

| | |
|----------------------|----------|
| 1M Extension (white) | A2044300 |
| 87° bend (white) | A2044700 |
| 2x45° elbows (white) | A2044500 |
| 1M Extension (black) | A2044200 |
| 87° bend (black) | A2044600 |
| 2x45° elbows (black) | A2044400 |

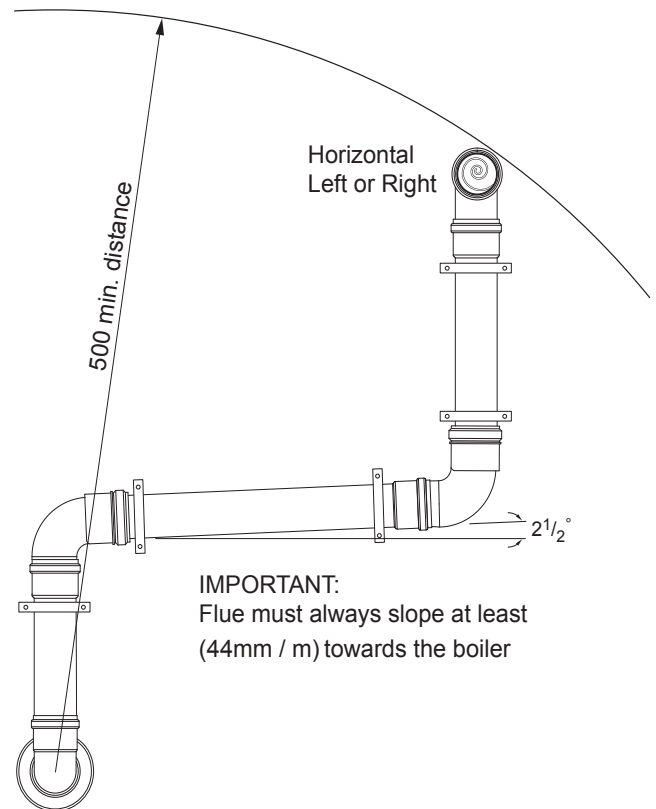

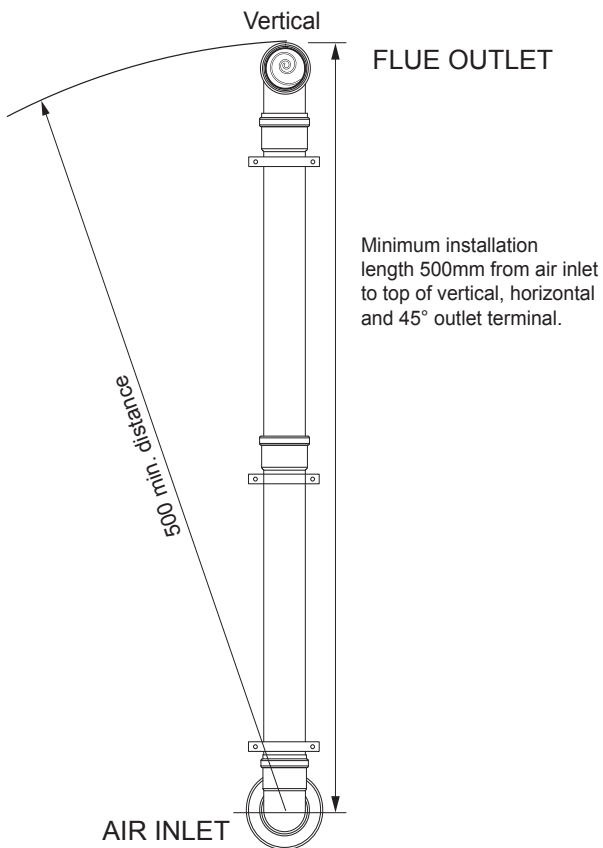
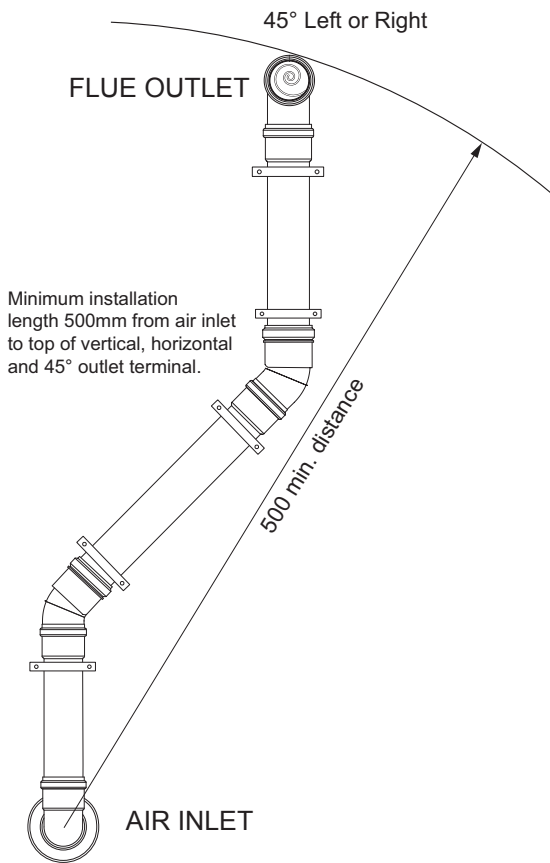

6.7 Installation

The plume management kit can be fitted when the appliance and flue are being fitted, or after the appliance and flue have been installed.

Use a 8mm. flat screwdriver to bend catches inwards.

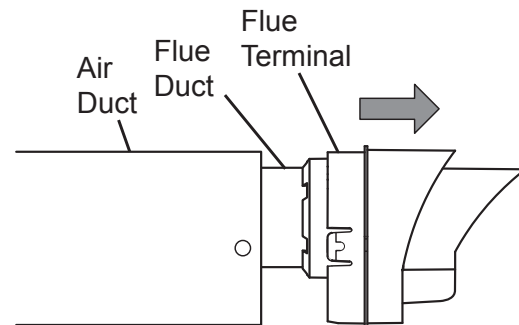
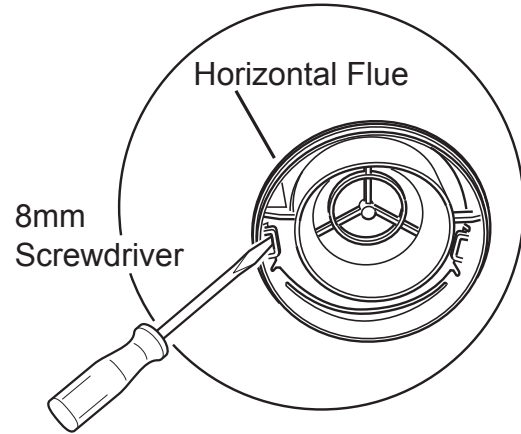

Remove the flue terminal and flue duct.

Remove the flue pipe from the flue terminal by twisting them against each other.

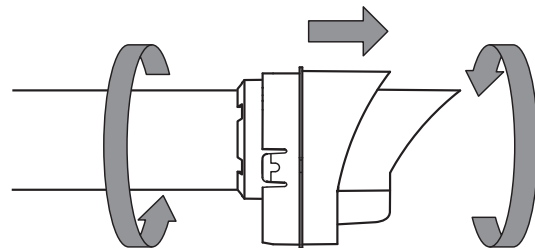

Push the wall connector onto the flue duct.

NOTE: the catch on top (inside) of the wall connector must lock firmly into the notch on top of the flue duct.

Fit the rubber collar.

Push the flue duct and wall connector into the air duct make sure the seals fit tightly.

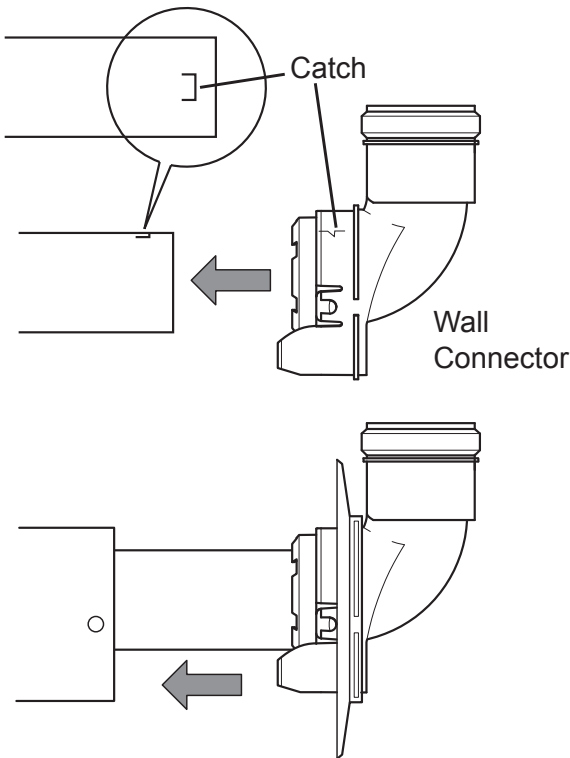

NOTE: The seam of the air duct must be at the top.

If the appliance has not been fitted, continue as described in the installation, instructions supplied with the appliance.

Using the 1M pipes, pipe fixing clips and 87° bend with bird protection build the (All push fit) plume management kit from the fitted wall connector to the selected location for the flue exit. Ensuring the joints are totally sealed. The flue pipes will expand when heated leave 1cm expansion gap in each connection.

Using the pipe fixing brackets supplied, secure the straight pipe to the wall.



The first bracket must be positioned as close to the Wall Connector as possible.

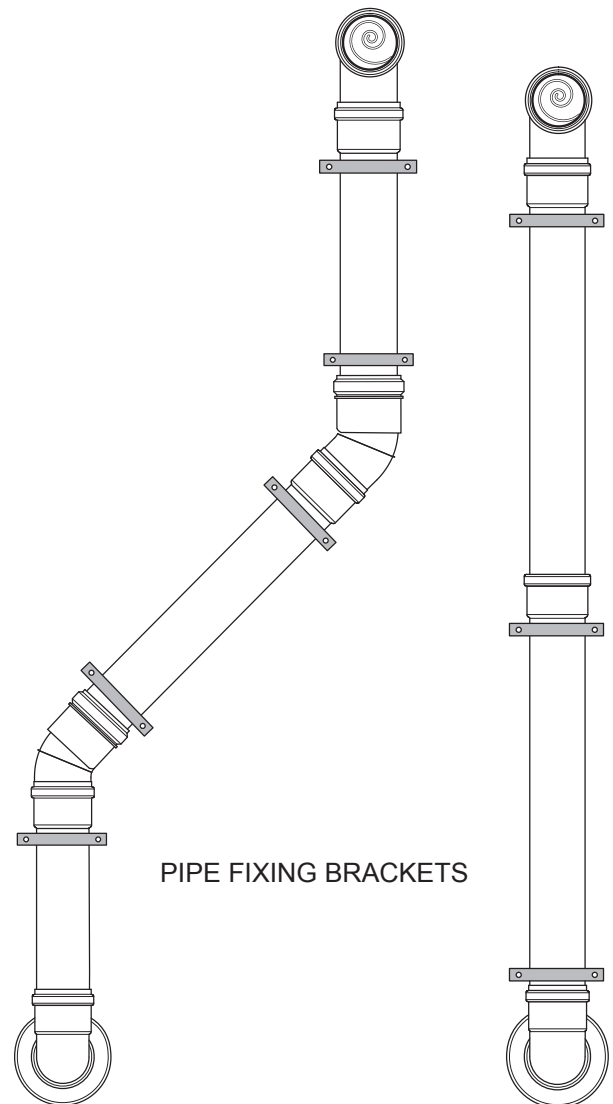

The straight pipe must be secured every metre and at each change of direction so more brackets may be required (3 supplied).



The flue should always have a fall of at least 2 1/2° (44mm/metre) towards the appliance.

When cutting 1M pipes to desired length, cut the opposite end to the seal and remove all burrs.



The flue seals are sensitive to mineral oil based lubricants. Do not grease the seals. If the seals do need to be lubricated use only water.



Take care when inserting not to push out the seals.

Additional pipe, 87° bends and 45° elbows may be used as necessary.

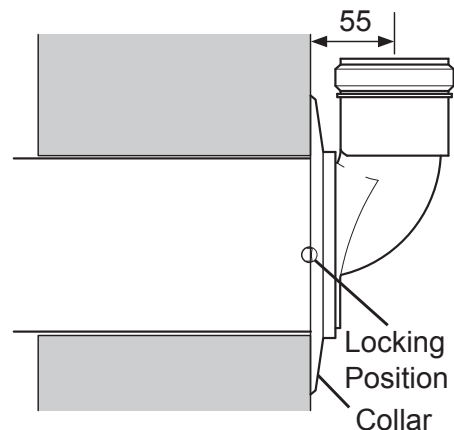

6.8 Termination above eaves

The Horizontal termination should be terminated 100mm above the eaves. The vertical flue outlet should be a minimum distance of 300mm above the eaves.

Exposed site conditions may require that the flue be secured as described in diagram.

6.9 Termination

The termination can be changed from 87° horizontal to 45° or vertical.

To achieve this remove the wire bird protection guard from the 87° Bend. Remove the O-ring seal from the 1M Pipe or 45° elbow and fit the wire bird protection guard into the 1M Pipe or 45° elbow where the O-ring seal was fitted.

It is not necessary to fit a terminal guard over the appliance main flue outlet. However should the plume management kit terminal discharge in a place where it requires protection, a guard should be fitted.

6.10 Fixing Instructions

These instructions are supplied to enable the flue pipe from the Plume Management Assembly to be securely fixed either at the eaves or on the gable end of a building when the flue terminal is to be terminated above the roof.

The stud bolt and wall plate fixings can be obtained from kit pt. no. A2043900 and used with the pipe fixing bracket supplied.

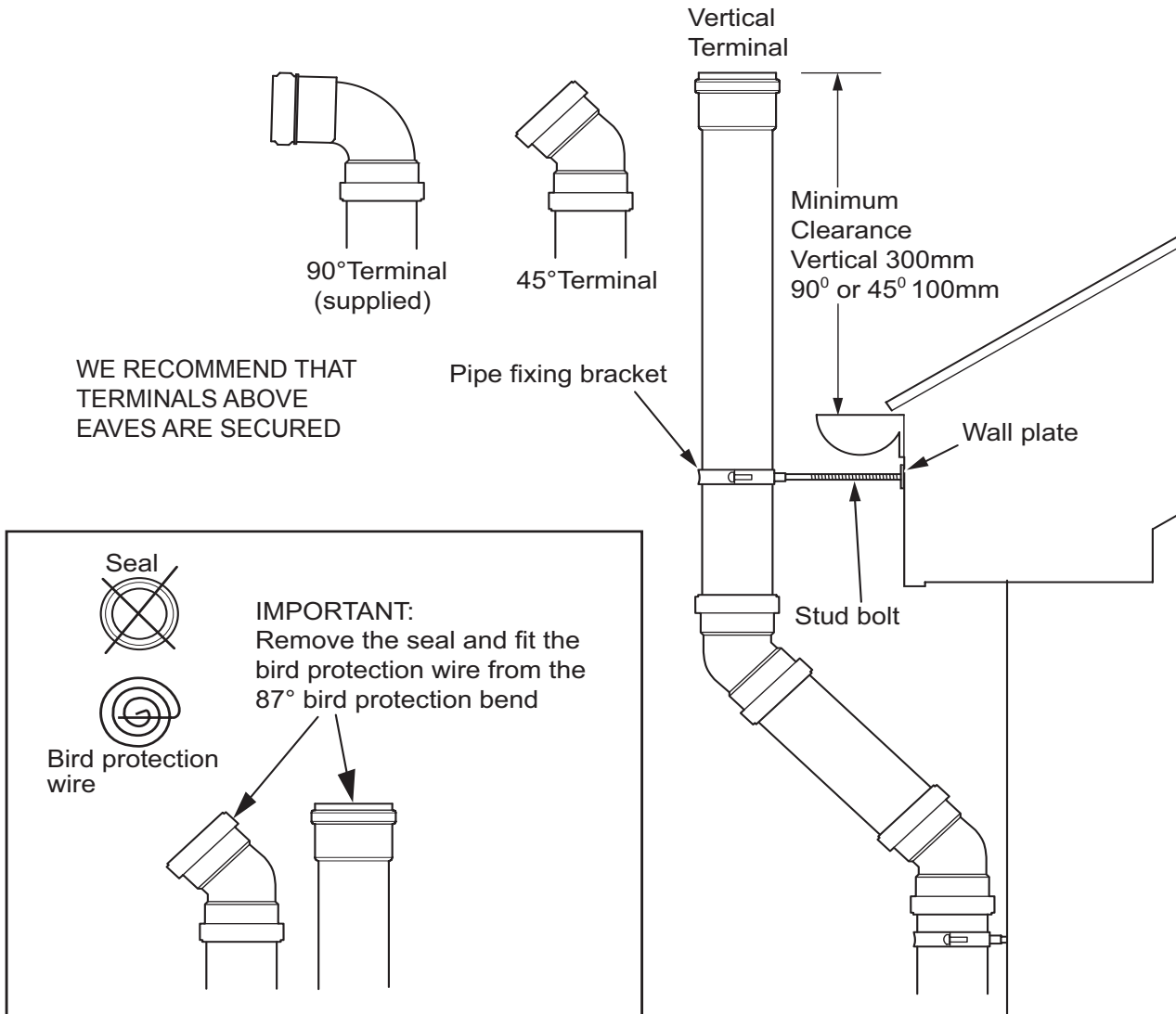

7 Flue Systems and Components

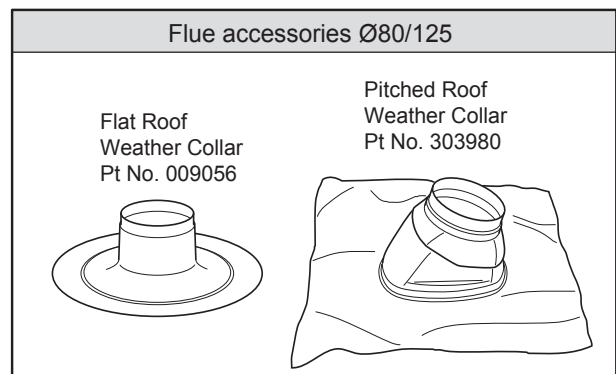
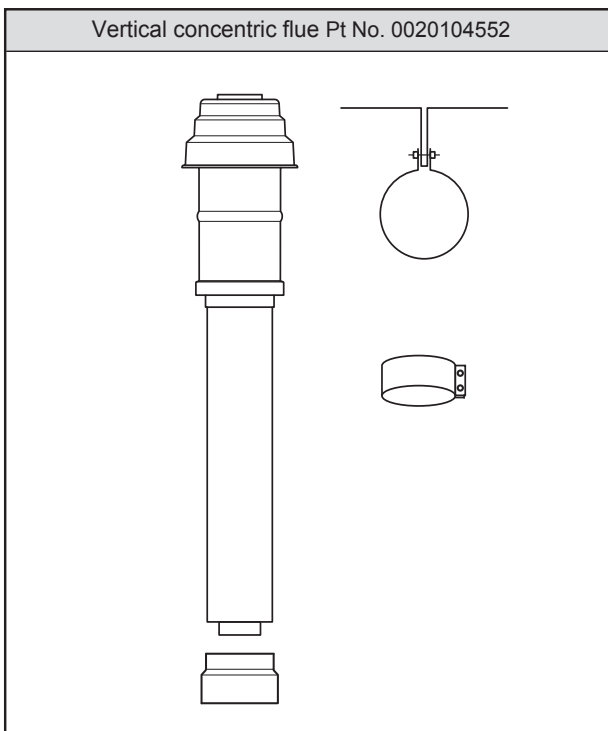
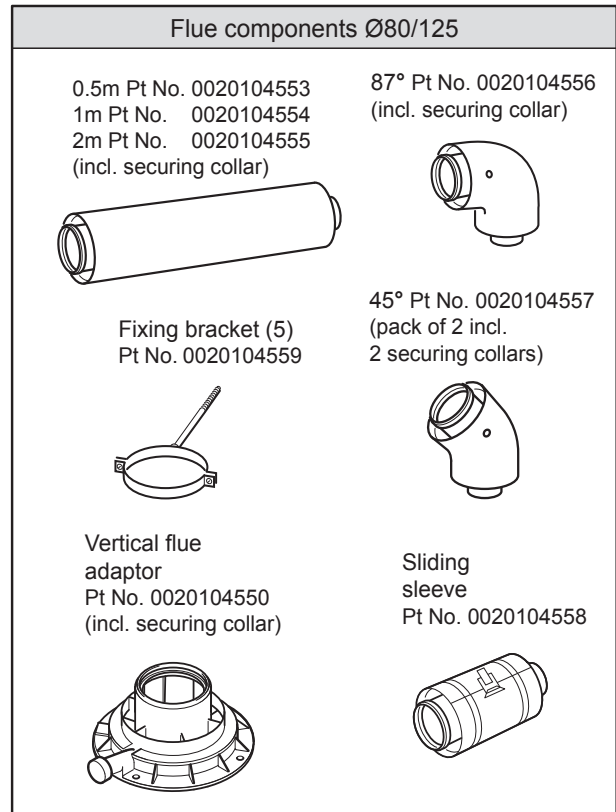
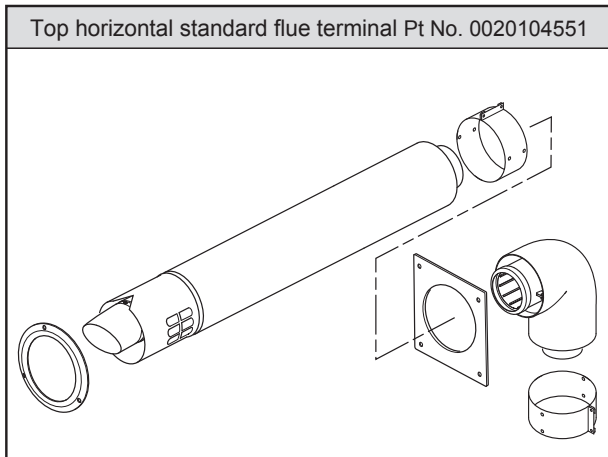
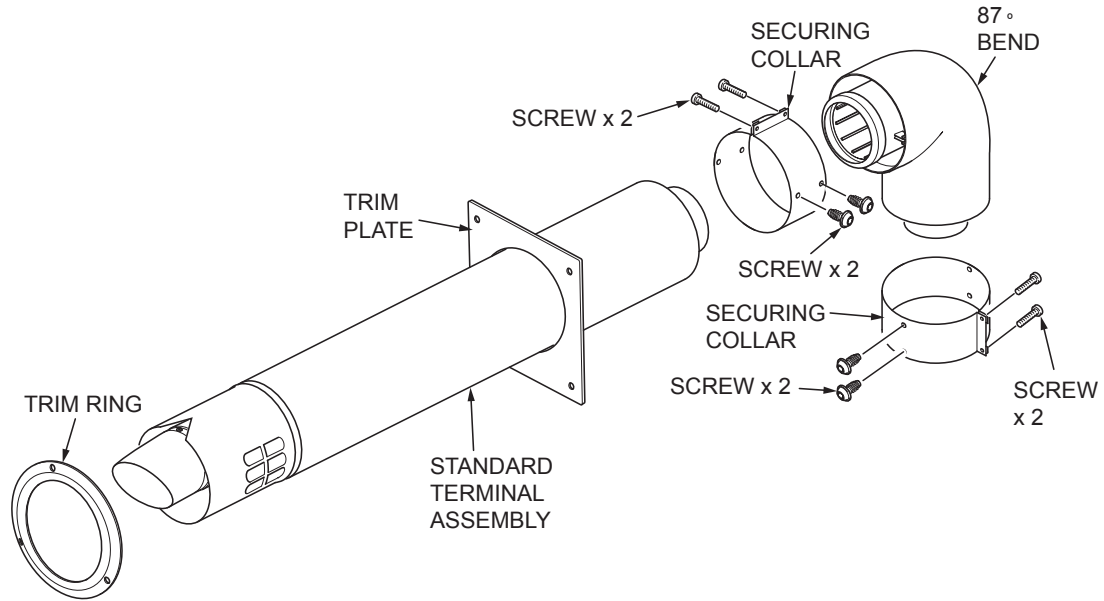

7.1 Top Horizontal Standard Flue Ø80/125

Refer to diagram 1 and check the contents of your kit.

Make sure you have all the necessary components before proceeding with the installation.

7.2 Flue Length and Terminal Position

Refer to your Installation instructions supplied with the appliance to confirm the flue length available and location of the flue terminal, then proceed as follows:

- Secure the flue adapter in position on top of the appliance with four screws supplied.

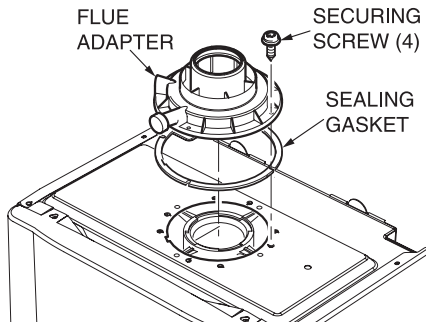

NOTE: Make sure the nib fits into the locating slot in the appliance casing to ensure correct orientation.

- With the flue elbow temporarily fitted, measure the distance from the external wall to the elbow.

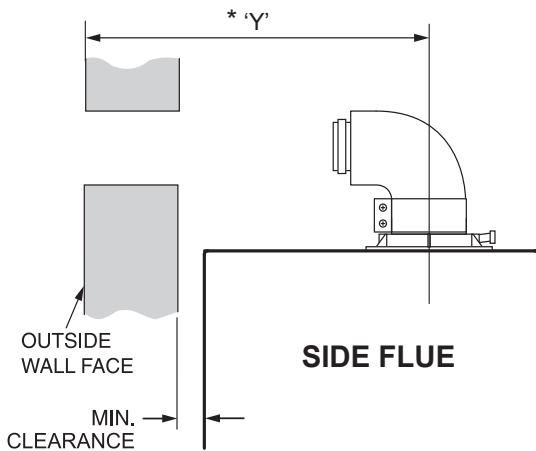

- If the measurement 'Y' exceeds the achievable flue length, 960mm, then the appropriate length of extension pipe is required.

7.3 Extension Cutting

- Separate the flue duct from the terminal by twisting to release from the securing catch inside the air/flue duct
- When cutting, cut equal amounts off the air duct and flue duct.
- When joining extensions leave a gap of 5mm between each air duct this will leave a correct flue duct connection of 30mm.

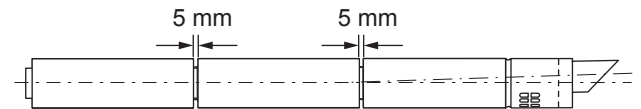
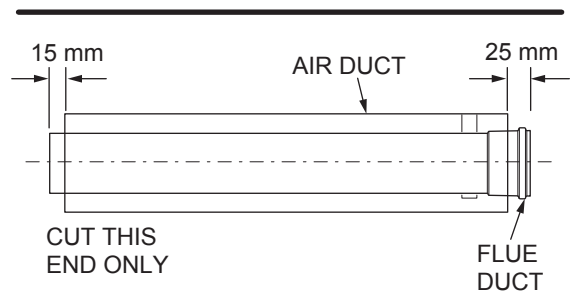
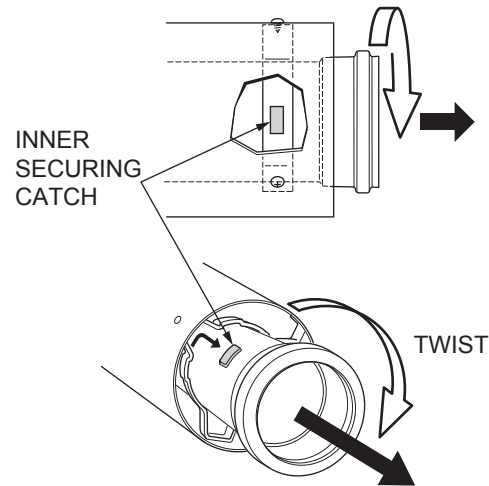

NOTE: For assembly reasons do not shorten any air duct to a length of less than 100mm. If necessary shorten two adjacent extensions to achieve the overall required length.

NOTE: For installations where there is insufficient movement to allow fitting of the flue into flue outlet, a sliding sleeve is available Part No. 0020104558. When using the sliding sleeve both the air and flue ducts of the last extension must be shortened by a further 85mm.

7.4 Installing the Sliding Sleeve

Push the sliding sleeve (1) over the cut end of the flue duct (2). Pull back the sliding sleeve so that it engages into the socket (3) of the boiler (4). Ensure that the sliding sleeve penetrates the socket such that there is at least 20 mm engagement at both ends of the sliding sleeve. Fit the air duct clamp (7) over the air ducts (5 and 6) of the extension/terminal and boiler outlet. Close the snap clamp.

Drill two holes 3mm diameter through the air duct clamp (7) (the centre of the holes should be 6mm from the edge of the clamp). Ensure that the drill does not penetrate the inner flue duct. Screw the air duct clamp to the air duct of the sleeve using the screws provided.

Complete the installation of the flue as detailed in these instructions.

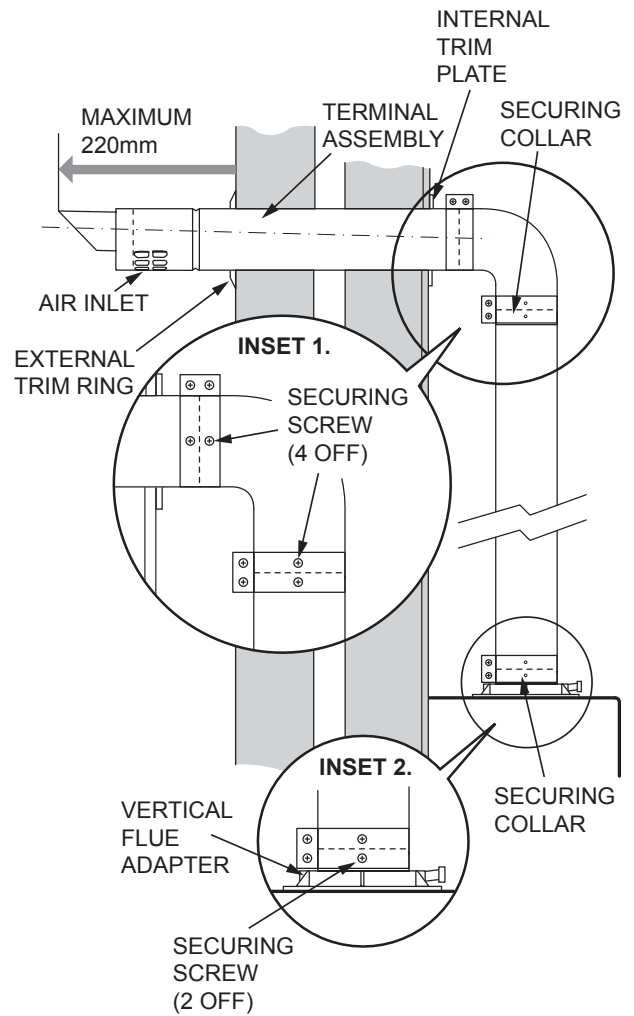
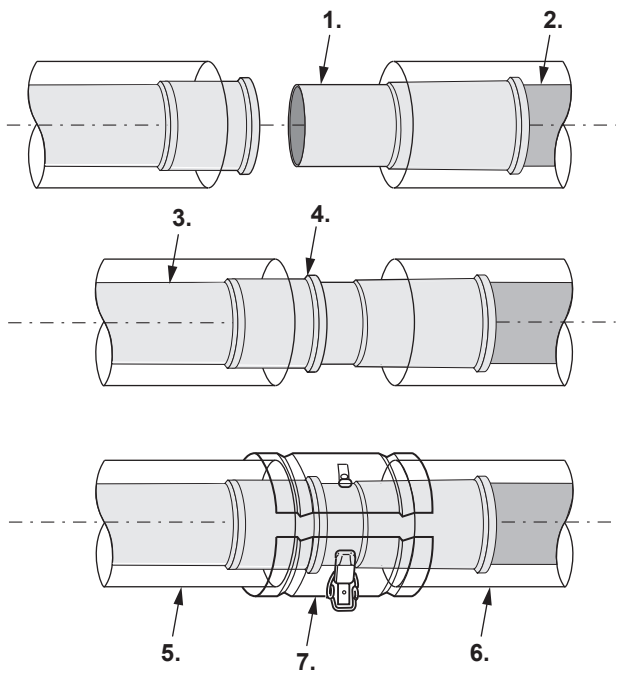

7.5 Fitting Elbows



The elbows must be correctly aligned to avoid undue stress on the joints and risk of leakage.

- The elbow fitted to the top of the boiler (1) should be twisted by 3° to ensure that the second 87° elbow (2) exits the wall perpendicular.

7.6 Flue Terminal Assembly Fitting

- Push the flue terminal assembly into the wall, externally or internally, until the end of the assembly protrudes a short way from the inside face of the wall. This will enable the assembly to be drawn back into the flue elbow on top of the flue adapter.
- Fit the internal trim plate.
- Secure the flue elbow with the securing collar in position on top of the vertical flue adapter.
- Ensuring correct alignment of the flue terminal assembly to the flue elbow and secure with the securing collar.
- Mark through two of the pre drilled holes in the securing collars.
- Drill 3mm diameter holes, take care not to pierce the inner flue duct.
- Secure the securing collars to the air duct, see inset 1.
- Make good the external wall face and fit the external trim ring.

NOTE: The air inlet must protrude completely beyond the face of the external wall and the external trim ring.

On completion of flue installation, continue with the appliance installation, referring to the appropriate section of the appliance installation instructions supplied.

7.7 Horizontal Flue Roof Termination

Order the flue flashing from from Ubbink, Northants, Telephone 01280 700211.

- Follow the previous instructions and the diagram below, to prepare the flue and follow the instructions supplied with the flashing.

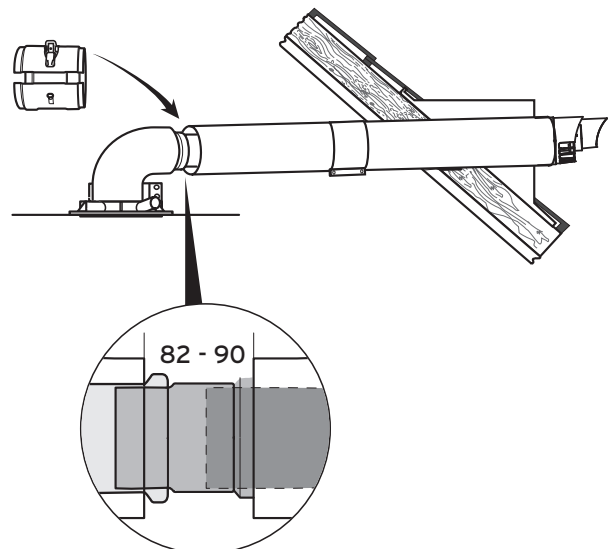

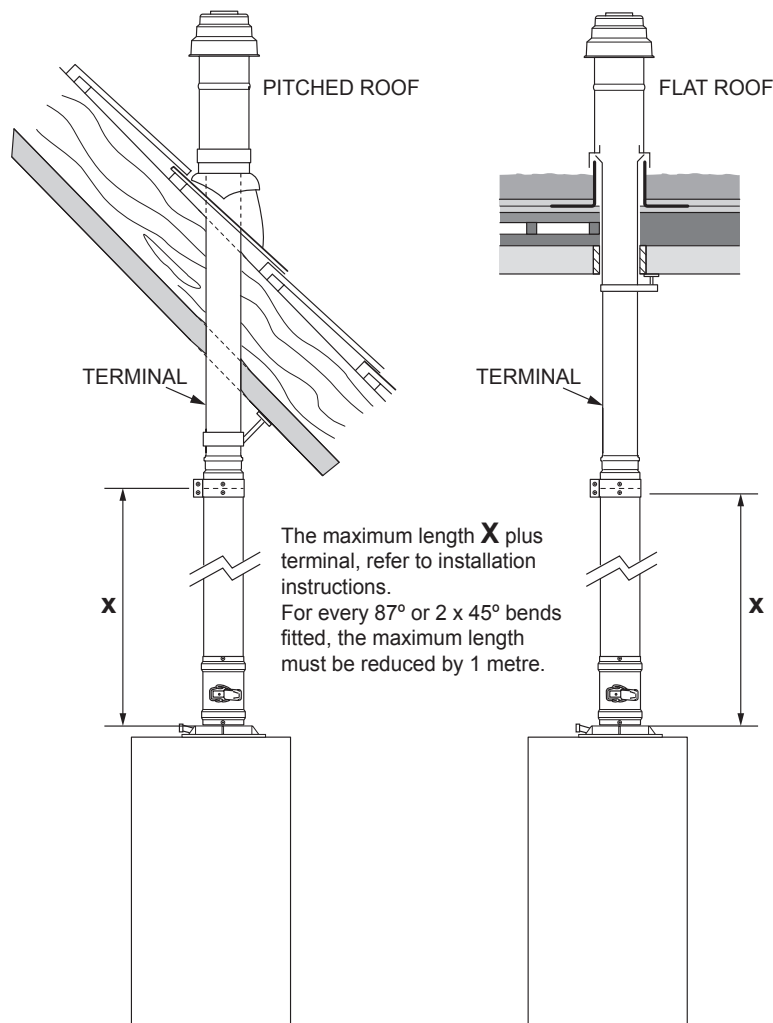

7.8 Vertical Concentric Flue Ø80/125

Check the contents of your kit.

Make sure you have all the necessary components before proceeding with the installation.

7.9 Flue Length and Terminal Position

Determine your maximum flue length and terminal position required, as described in your installation instructions supplied with your appliance, then proceed as follows:

- Secure the flue adapter in position on top of the appliance with four screws supplied.

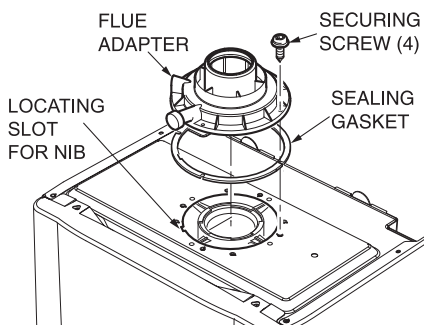

NOTE: Make sure the nib fits into the locating slot in the appliance casing to ensure correct orientation.

- Fit the flue terminals as described in the following paragraphs, pitched or flat roof.
- Measure the flue lengths required. In case of installation directly to the boiler without elbows, it is essential that the roof tile/collar is vertically aligned with the air/ flue duct of the boiler.

7.10 Pitched Roof Terminal Installation

- Determine the point where the vertical air/flue duct and terminal assembly will exit the roof.
- Fit the flexible pitched roof weather collar (2) over the 125mm. hole in the roof. Make good the tiling or slating around the collar incorporating the flashing of the weather collar.
- Position the angle cap over the weather collar in the correct orientation to attain the correct angle for your roof.
- Working from above, insert the vertical roof duct (1) through the roof tile and push it firmly into place.
- Vertically align the roof duct and attach it to the roof structure with the fixing bracket (3) supplied.
- Fit the boiler hanging bracket and install the appliance with reference to the installation and servicing instructions supplied with the appliance.

7.11 Flat Roof Terminal Installation

Determine the point where the vertical air/flue duct and terminal assembly will exit the roof.

- Fit the aluminium weather collar (2).
- Stick the flat roof penetration collar firmly into place with adhesive in accordance with the codes of practice for flat roofs (CP 144) to ensure a watertight seal.
- Working from above, insert the vertical roof duct (1) through the flat roof collar and push it firmly into place.
- Vertically align the roof duct and attach it to the roof structure with the fixing bracket (3) supplied.
- Fit the boiler hanging bracket and install the appliance with reference to the installation and servicing instructions supplied with the appliance.

7.12 Flue Terminal Cutting

DO NOT CUT THE FLUE TERMINAL should the clearances above the appliance to the flue terminal not allow for extensions.

7.13 Fitting Air/Flue Duct Extensions

With the flue terminal positioned in the roof, complete the connection between terminal and adapter.

- Separate the flue duct from the terminal by twisting to release from the securing catch inside the air/flue duct
- When cutting, cut equal amounts off the air duct and flue duct.
- When joining extensions leave a gap of 5mm. between each air duct this will leave a correct flue duct connection of 30mm.

NOTE: For assembly reasons do not shorten any air duct to a length of less than 80 mm. If necessary shorten two adjacent extensions to achieve the overall required length.

NOTE: See Fitting air/flue duct extensions / Fitting elbows for further details on the installation of extensions and elbows.

- Push the sliding sleeve (6) firmly into place on the extension.
- Join the vertical roof duct (1) to the extension (4).
- Join the sliding sleeve (6) to the vertical flue adapter (5).



Using the sliding sleeve allows the appliance to be easily removed and replaced without dismantling the flue.

- Drill two holes 3mm Ø through the air duct of the flue/boiler clamp at the most convenient holes on the air duct securing clamp. (Ensure that the drill does not penetrate the inner flue duct). Screw the air duct securing clamp to the air ducts of the flue assembly and the vertical flue adapter using the screws supplied.
- Ensure that any air duct securing clamps used are positioned centrally and fixed to the air duct using the self tapping screws supplied.



The air duct securing clamp MUST NOT be screwed to the bottom of the vertical air/flue duct and terminal accessory, this will allow for any slight movement in the roof structure.

- Ensure that at least one fixing bracket supports the air/ flue duct at each extension fitted.

7.14 Fitting Elbows



The elbows must be correctly aligned to avoid undue stress on the joints and risk of leakage.

- The elbow fitted to the top of the boiler (1) should be twisted by 3° to ensure that the second 87° elbow (2) exits the wall perpendicular.

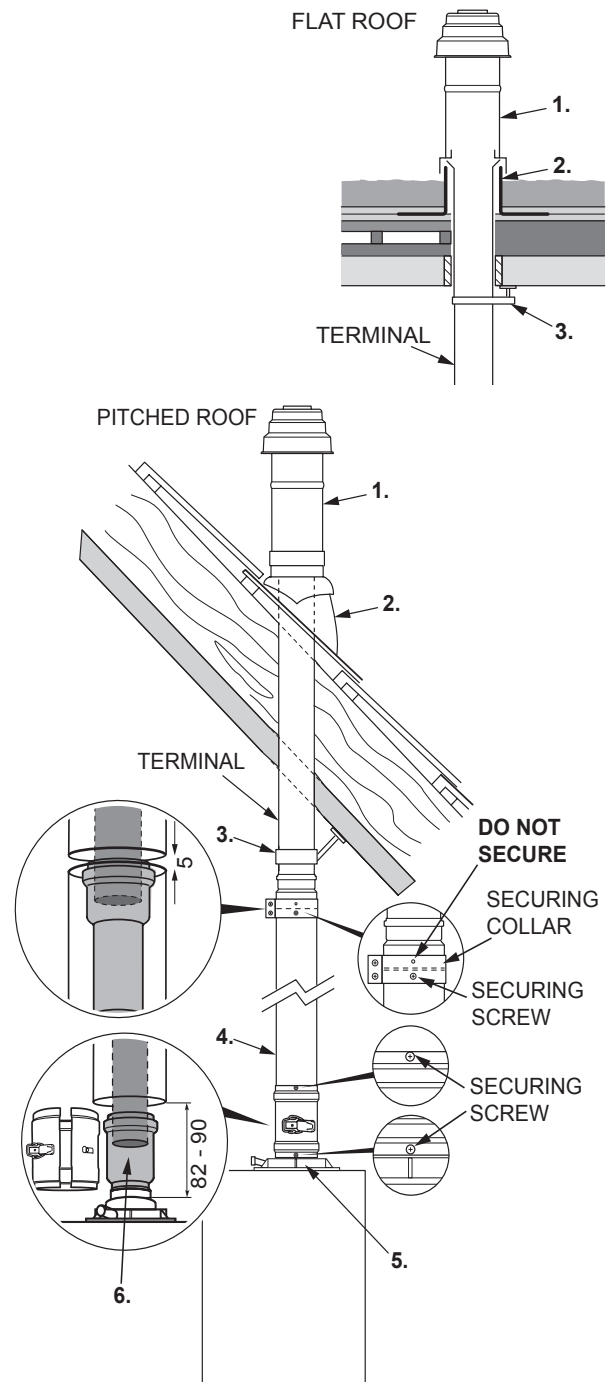



GLOW-WORM

Nottingham Road,
Belper, Derbyshire.
DE56 1JT

www.glow-worm.co.uk

Because of our constant endeavour for
improvement, details may vary slightly
from those shown in these instructions.

Glow•worm

Subject to engineering changes

0020095198 - 02/11